



Bonfiglioli

Vectron

ACTIVE and ACTIVE Cube

Expansion Module EM-ENC-01
Frequency Inverter 230V / 400V



General points on the documentation

The present supplement of the documentation is valid for the frequency inverter series ACT and ACU. The information necessary for the assembly and application of the EM-ENC-01 expansion module is documented in this guidance.

For better clarity, the user documentation is structured according to the customer-specific demands made of the frequency inverter.

Brief instructions

The brief instructions describe the fundamental steps for mechanical and electrical installation of the frequency inverter. The guided commissioning supports you in the selection of necessary parameters and the software configuration of the frequency inverter.

Operating instructions

The operating instructions document the complete functionality of the frequency inverter. The parameters necessary for specific applications for adaptation to the application and the extensive additional functions are described in detail.

Application manual

The application manual supplements the documentation for purposeful installation and commissioning of the frequency inverter. Information on various subjects connected with the use of the frequency inverter is described specific to the application.

Installation Instructions

Complementing the Brief Instructions and the Operating Instructions, the Installation Instructions provide information on how to install and use the additional/optional components.

The documentation and additional information can be requested via your local representation of the company of BONFIGLIOLI.

The following pictograms and signal words are used for the purposes of the present documentation:

Danger!

means a directly threatening danger. Death, serious damage to persons and considerable damage to property will occur if the precautionary measure is not taken.



Warning!

marks a possible threat. Death, serious damage to persons and considerable damage to property can be the consequence if attention is not paid to the text.



Caution!

refers to an indirect threat. Damage to people or property can be the result.

Attention!

refers to a possible operational behavior or an undesired condition, which can occur in accordance with the reference text.

Note

marks information, which facilitates handling for you and supplements the corresponding part of the documentation.



Warning! In installation and commissioning, comply with the information in the documentation. You as a qualified person must have read the documentation carefully and understood it. Comply with the safety instructions. For the purposes of the instructions, "qualified person" designates a person acquainted with the erection, assembly, commissioning and operation of the frequency inverters and possessing the qualification corresponding to the activity.

TABLE OF CONTENTS

| | |
|--|-----------|
| General points on the documentation | 1 |
| General safety and application information | 4 |
| 1.1 General information..... | 4 |
| 1.2 Proper use..... | 4 |
| 1.3 Transport and storage | 5 |
| 1.4 Handling and positioning..... | 5 |
| 1.5 Electrical connection..... | 5 |
| 1.6 Operation information | 5 |
| 1.7 Maintenance and service | 5 |
| 2 Introduction | 6 |
| 3 Installation of the EM-ENC-01 expansion module..... | 7 |
| 3.1 General | 7 |
| 3.2 Mechanical installation | 7 |
| 3.3 Electrical installation | 9 |
| 3.3.1 Circuit diagram | 9 |
| 3.3.2 Sockets..... | 10 |
| 4 System bus interface..... | 11 |
| 4.1 Bus termination | 11 |
| 4.2 Cables | 12 |
| 4.3 Socket X410B..... | 12 |
| 4.4 Baud rate setting/line length | 13 |
| 4.5 Setting node address | 13 |
| 4.6 Functional overview | 14 |
| 4.7 Network management..... | 14 |
| 4.7.1 SDO channels (parameter data) | 15 |
| 4.7.2 PDO channels (process data)..... | 16 |
| 4.8 Master functionality..... | 17 |
| 4.8.1 Control boot-up sequence, network management..... | 17 |
| 4.8.2 SYNC telegram, generation..... | 19 |
| 4.8.3 Emergency message, reaction..... | 20 |
| 4.8.4 Client SDO (system bus master)..... | 21 |
| 4.9 Slave functionality | 22 |
| 4.9.1 Implement boot-up sequence, network management..... | 22 |
| 4.9.1.1 Boot-up message | 22 |
| 4.9.1.2 Status control | 22 |
| 4.9.2 Process SYNC telegram | 23 |
| 4.9.3 Emergency message, fault switch-off..... | 24 |
| 4.9.4 Server SDO1/SDO2 | 25 |
| 4.10 Communication channels, SDO1/SDO2..... | 27 |
| 4.10.1 SDO telegrams (SDO1/SDO2) | 27 |
| 4.10.2 Communication via field bus connection (SDO1)..... | 29 |
| 4.10.2.1 Profibus-DP | 29 |
| 4.10.2.2 RS232/RS485 with VECTRON bus protocol | 29 |

TABLE OF CONTENTS

| | | |
|-------------|--|-----------|
| 4.11 | Process data channels, PDO | 31 |
| 4.11.1 | Identifier assignment process data channel..... | 31 |
| 4.11.2 | Operation modes process data channel..... | 32 |
| 4.11.3 | Timeout monitoring process data channel..... | 33 |
| 4.11.4 | Communication relationships of the process data channel | 34 |
| 4.11.5 | Virtual links | 35 |
| 4.11.5.1 | Input parameters of the TxPDO's for data to be transmitted | 38 |
| 4.11.5.2 | Source numbers of the RxPDO's for received data..... | 40 |
| 4.11.5.3 | Examples of virtual links | 41 |
| 4.12 | Control parameters..... | 42 |
| 4.13 | Handling of the parameters of the system bus | 43 |
| 4.14 | Utilities | 45 |
| 4.14.1 | Definition of the communication relationships..... | 46 |
| 4.14.2 | Production of the virtual links..... | 47 |
| 4.14.3 | Capacity planning of the system bus..... | 48 |
| 5 | Control inputs and outputs | 50 |
| 5.1 | Analog input EM-S1INA | 50 |
| 5.1.1 | General..... | 50 |
| 5.1.2 | Configuration voltage/current input | 50 |
| 5.1.3 | Characteristic | 51 |
| 5.1.4 | Operation modes | 51 |
| 5.1.4.1 | Examples..... | 52 |
| 5.1.5 | Scaling..... | 54 |
| 5.1.6 | Tolerance band and hysteresis..... | 55 |
| 5.1.7 | Error and warning behavior | 56 |
| 5.1.8 | Adjustment | 57 |
| 5.1.9 | Filter time constant..... | 58 |
| 5.2 | Speed sensor input EM-ENC | 58 |
| 5.2.1 | Termination resistor..... | 59 |
| 5.2.2 | Division marks..... | 60 |
| 5.2.3 | Actual speed source..... | 60 |
| 5.2.4 | Actual value comparison..... | 61 |
| 5.3 | Frequency and percentage reference channel | 61 |
| 5.4 | Actual value display | 61 |
| 5.5 | Repetition frequency output EM-RFOUT | 62 |
| 5.5.1 | Division marks..... | 62 |
| 5.5.2 | Ramp | 63 |
| 5.5.3 | Examples | 63 |
| 6 | Parameter list..... | 64 |
| 6.1 | Actual value menu (VAL) | 64 |
| 6.2 | Parameter menu (PARA) | 64 |
| 7 | Annex | 66 |
| 7.1 | Error messages | 66 |

1 General safety and application information

This documentation has been created with greatest care and has been extensively and repeatedly checked. For reasons of clarity, we have not been able to take all detailed information on all the types of the products and also not every imaginable case of positioning, operation or maintenance into account. If you require further information or if particular problems not treated extensively enough in the operating instructions occur, you can obtain the necessary information via the local representation of the company BONFIGLIOLI.

In addition, we would point out that the contents of these operating instructions are not part of an earlier or existing agreement, assurance or legal relationship, nor are they intended to amend them. All the manufacturer's obligations result from the purchase contract in question, which also contains the completely and solely valid warranty regulation. These contractual warranty provisions are neither extended nor limited by the implementation of these operating instructions.

The manufacturer reserves the right to correct or amend the contents and product information as well as omissions without specific announcement and assumes no kind of liability for damage, injuries or expenditure to be put down to the aforementioned reasons.

1.1 General information



Warning! BONFIGLIOLI VECTRON frequency inverters have high voltage levels during operating, depending on their protection class, drive moving parts and have hot surfaces.

In the event of inadmissible removal of the necessary covers, improper use, wrong installation or operation, there is the risk of serious damage to persons or property.

To avoid the damage, only qualified staff may carry out the transport, installation, setup or maintenance work required. Comply with the standards EN 50178, IEC 60364 (Cenelec HD 384 or DIN VDE 0100), IEC 60664-1 (Cenelec HD 625 or VDE 0110-1), BGV A2 (VBG 4) and national provisions. Qualified persons within the meaning of this principal safety information are people acquainted with the erection, fitting, commissioning and operating of frequency inverters and the possible hazards and in possession of qualifications matching their activities.

1.2 Proper use



Warning! The frequency inverters are electrical drive components intended for installation in industrial plant or machines. Commissioning and start of intended operation are not allowed until it has been established that the machine corresponds to the provisions of the EC machine directive 98/37/EEC and EN 60204. According to the CE sign, the frequency inverters additionally fulfill the requirements of the low-voltage directive 73/23/EEC and the standards EN 50178 / DIN VDE 0160 and EN 61800-2. Responsibility for compliance with the EMC directive 89/336/EEC is with the user. Frequency inverters are available in a limited way and as components exclusively intended for professional use within the meaning of the standard EN 61000-3-2.

With the issue of the UL certificate according to UL508c, the requirements of the CSA Standard C22.2-No. 14-95 have also been fulfilled.

The technical data and the information on connection and ambient conditions stated on the rating plate and the documentation must be complied with. The instructions must have been read and understood before starting work at the device.

1.3 Transport and storage

Transport and storage are to be done appropriate in the original packing. Store the units only in dry rooms, which are protected against dust and moisture and are subjected to little temperature deviations only. Observe the climatic conditions according to standard EN 50178 and to the information on the label of the original packing. The duration of storage without connection to the admissible reference voltage may not exceed one year.

1.4 Handling and positioning



Warning! Damaged or destroyed components may not be put into operation because they may be a health hazard.

The frequency inverters are to be used according to the documentation, the directives and the standards. Handle carefully and avoid mechanical overload. Do not bend the components or change the isolation distances. Do not touch electronic components or contacts. The devices contain construction elements with a risk of electrostatic, which can easily be damaged by improper handling. Any use of damaged or destroyed components shall be considered as a non-compliance with the applicable standards. Do not remove any warning signs from the device.

1.5 Electrical connection



Warning! Before any assembly or connection work, de-energize the frequency inverter.

Do not touch the sockets, because the capacitors may still be charged.

Make sure that the frequency inverter is de-energized.

Comply with the information given in the operating instructions and on the frequency inverter label.

While working on the frequency inverters, obey the applicable standards BGV A2 (VBG 4), VDE 0100 and other national directives. Comply with the information in the documentation on electrical installation and the relevant directives. Responsibility for compliance with and examination of the limit values of the EMC product standard EN 61800-3 for variable-speed electrical drive mechanisms is with the manufacturer of the industrial plant or machine.

The documentation contains information on installation correct for EMC. The cables connected to the frequency inverters may not be subjected to an isolation test with a high test voltage without previous circuit measures.

1.6 Operation information



Warning! Before commissioning and the start of the intended operation, attach all the covers and check the sockets. Check additional monitoring and protective devices pursuant to EN 60204 and the safety directives applicable in each case (e.g. Working Machines Act, Accident Prevention Directives etc.).

No connection work may be performed, while the system is in operation.

1.7 Maintenance and service



Warning! Unauthorized opening and improper interventions can lead to physical injury or damage to property. Repairs on the frequency inverters may only be done by the manufacturer or persons authorized by the latter.

2 Introduction

This document describes the possibilities and the properties of the EM-ENC-01 expansion module for the frequency inverters of the ACT and ACU device series.

Note: This document exclusively describes the EM-ENC-01 expansion module. It does not provide basic information on the operation of the ACT and ACU series frequency inverters.

The EM-ENC-01 expansion module is an optional hardware component to extend the functionality of the frequency inverter. It enables the data exchange within the network between the components which have been directly connected, for example control and regulation elements.

The EM-ENC-01 expansion module is supported from device series ACU and as from software version 4.1.0 of device series ACT.

The EM-ENC-01 module extends the functionality of the frequency inverters of the ACT and ACU series of devices by the following additional functions:

- **CAN system bus**
(CAN interface ISO-DIS 11898; CAN High Speed; max. 1 MBaud)
- **Analog input**
(second bipolar analog input)
- **Speed sensor input**
(second speed sensor input)
- **Repetition frequency output**
(speed sensor simulation)

Note: The EM-ENC-01 expansion module has been enclosed with the frequency inverter as a separate component and must be fitted by the user. This is described in detail in the chapter "Mechanical Installation".

To assemble the expansion module it can be easily plugged into the frequency inverters of the ACT and ACU device series.



Warning! The assembly is done before the frequency inverter is put into operation, and only in a voltage-free state.

The pluggable sockets of the expansion module enable economical overall fitting with a safe function.

3 Installation of the EM-ENC-01 expansion module

3.1 General

The mechanical and electrical installation of the EM-ENC-01 expansion module is to be carried out by qualified personnel according to the general and regional safety and installation directives. Safe operation of the frequency inverter requires that the documentation and the device specification be complied with in installation and start of operation. For specific areas of application further provisions and guidelines must be complied with where applicable.

The frequency inverters are designed according to the requirements and limit values of product norm EN 61800-3 with an interference immunity factor (EMI) for operation in industrial applications. The electromagnetic interference is to be avoided by expert installation and observation of the specific product information.

For further information, refer to the chapter "Electrical Installation" of the frequency inverter operating instructions.



Warning! All connection terminals where dangerous voltage levels may be present (e.g. motor connection terminals, mains terminals, fuse connection terminals, etc.), must be protected against direct contact.

3.2 Mechanical installation



Danger! If the following instructions are not complied with, there is direct danger with the possible consequences of death or severe injury by electrical current.
Further, failure to comply can lead to destruction of the frequency inverter and/or of the expansion module.

- Before assembly or disassembly of the EM-ENC-01 expansion module, the frequency inverter must be de-energized. Take appropriate measures to make sure it is not energized unintentionally.
- Make sure that the frequency inverter is de-energized.



Danger! The mains, direct voltage- and motor terminals can have dangerous voltages even after the frequency inverter has been disconnected. The expansion module may only be plugged on after a waiting period of some minutes until the DC link capacitors of the frequency inverter have discharged.

The EM-ENC-01 expansion module is supplied in a housing for assembly on the lower slot of the frequency inverter.

- Remove the lower cover (1) of the frequency inverter.
The slot for the EM-ENC-01 expansion module becomes accessible.

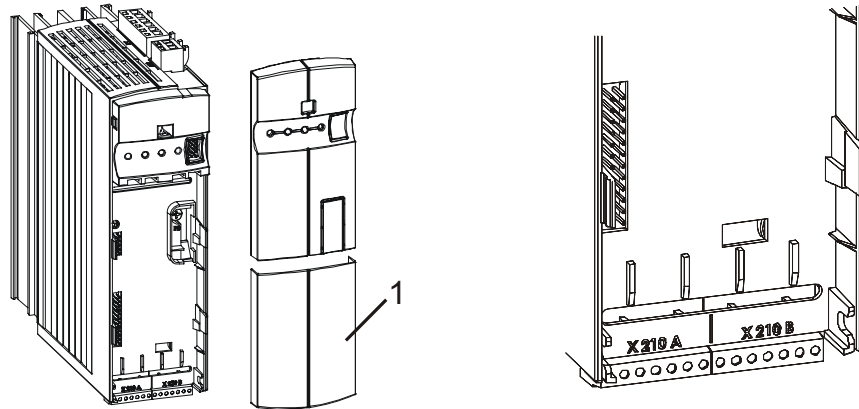

Caution! The EM-ENC-01 expansion module (2) is pre-fitted in a housing. The PCB visible on the back may not be touched, as modules can be damaged by this.

- Plug the EM-ENC-01 expansion module (2) onto the slot (3).

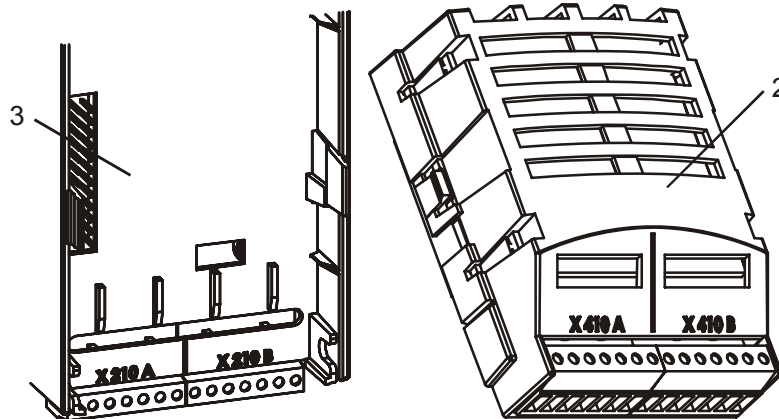

- Re-install the cover (1).
This completes the assembly procedure.

When the supply voltage of the frequency inverter is switched on, the EM-ENC-01 expansion module is ready for operation.

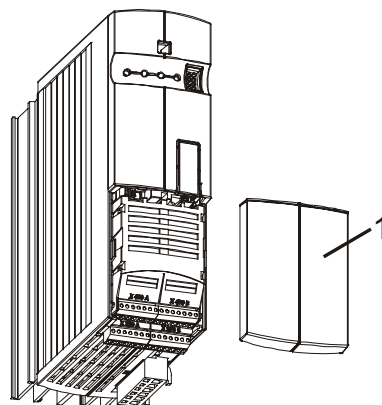

3.3 Electrical installation



Danger! If the following instructions are not complied with, there is direct danger with the possible consequences of death or severe injury by electrical current.

Further, failure to comply can lead to destruction of the frequency inverter and/or of the expansion module.

- Before assembly or disassembly of the EM-ENC-01 expansion module, the frequency inverter must be de-energized. Take appropriate measures to make sure it is not energized unintentionally.
- Make sure that the frequency inverter is de-energized.



Danger! The mains, direct voltage and motor terminals can have dangerous voltages even after the frequency inverter has been disconnected. The expansion module may only be plugged on after a waiting period of some minutes until the DC link capacitors of the frequency inverter have discharged.

3.3.1 Circuit diagram

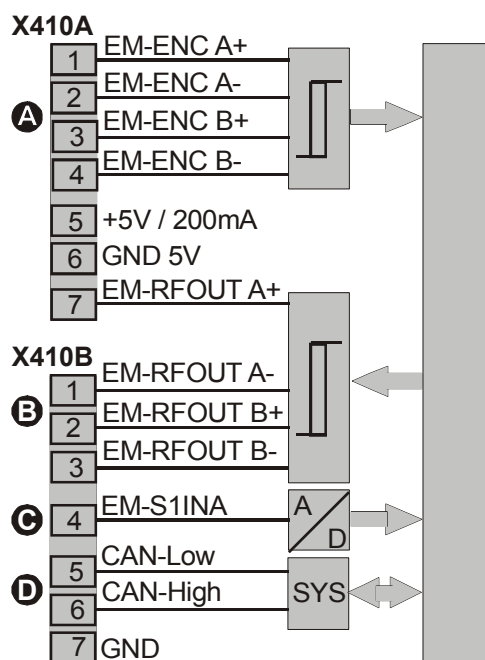

A Speed sensor input EM-ENC

Frequency signal, $f_{\max} = 300 \text{ kHz}$, voltage-proof until 30 V, TTL (push-pull) according to specification RS-422A / RS-485: $U_{\max} = 5 \text{ V}$, HTL (push-pull or unipolar): $I_{\max} = 12 \text{ mA}$ at 24 V

B Repetition frequency output EM-RFOUT

Frequency signal, $f_{\max} = 150 \text{ kHz}$, overload and short-circuit proof, $I_{\max} = \pm 60 \text{ mA}$ at min. permissible line termination 150Ω , according to specification EIA485

C Analog input EM-S1INA

Analog signal, resolution 12 Bit, $U_{\max} = \pm 10 \text{ V}$ ($R_i = 100 \text{ k}\Omega$), $I_{\max} = \pm 20 \text{ mA}$ ($R_i = 250 \Omega$)

D Communication interface system bus

CAN actuation of the system bus according to ISO-DIS 11898 (CAN High Speed)

3.3.2 Sockets

The control and software functionality can be freely configured for economical operation with a safe function. The operating instructions describe the factory setting of the standard connections in the *Configuration 30* in question and also the software parameters for the setting.

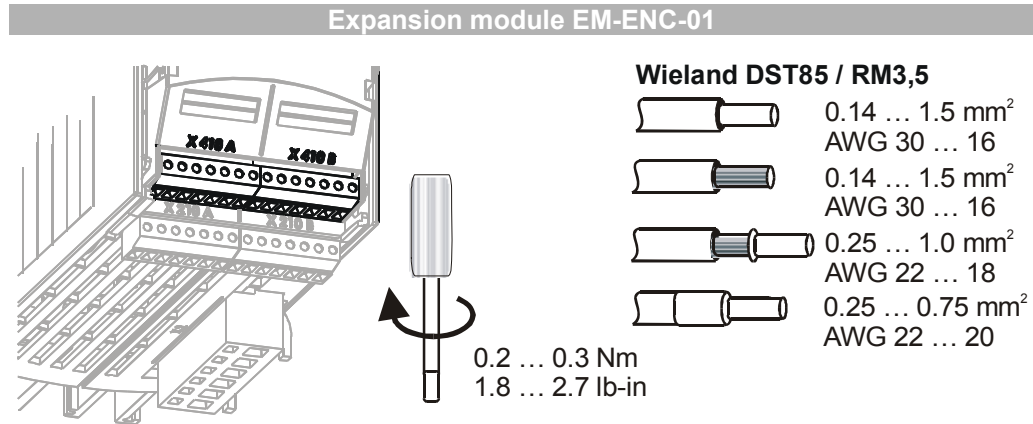

Caution! The control inputs and outputs must be connected and separated free of electrical power.

| Socket X410A | |
|--------------|---|
| Ter. | Description |
| 1 | Speed sensor input EM-ENC A+ |
| 2 | Speed sensor input EM-ENC A- |
| 3 | Speed sensor input EM-ENC B+ |
| 4 | Speed sensor input EM-ENC B- |
| 5 | Voltage output 5 V, $I_{\max} = 200 \text{ mA}$ ¹⁾ |
| 6 | Earth / GND 5 V |
| 7 | Repetition frequency output EM-RFOUT A+ ²⁾ |

| Socket X410B | |
|--------------|--|
| Ter. | Description |
| 1 | Repetition frequency output EM-RFOUT A- ²⁾ |
| 2 | Repetition frequency output EM-RFOUT B+ ²⁾ |
| 3 | Repetition frequency output EM-RFOUT B- ²⁾ |
| 4 | Analog input EM-S1INA, resolution 12 bit, $U_{\max} = \pm 10 \text{ V}$ ($R_i = 100 \text{ k}\Omega$), $I_{\max} = \pm 20 \text{ mA}$ ($R_i = 250 \Omega$) |
| 5 | System bus, CAN low |
| 6 | System bus, CAN high |
| 7 | Earth / GND |

¹⁾ The power supply of 20 V at terminal X210A.1 may be loaded with a maximum current of $I_{\max} = 180 \text{ mA}$. Relative to the application, the maximum current available will be reduced by the further control outputs in the basic device and the expansion module.

The voltage output of 5 V loads the power supply of the base device at a ratio of 1:4. This means a reduction of 50 mA at a load at the control terminal X410A.5 of 200 mA.

²⁾ The repetition frequency output is interference voltage proof in a range between -5 V to +10 V.

4 System bus interface

The CAN connection of the system bus is physically designed according to **ISO-DIS 11898** (CAN High Speed). The bus topology is the line structure.

In the default version, the frequency inverter support a CAN protocol controller, which may exist in **either** the CM-CAN communication module with CANopen interface **or** in an expansion module for the system bus, such as the EM-ENC-01 expansion module.

Attention! Installation of two optional components with CAN-Protocol controller results in a deactivation of the system bus interface in the EM-ENC-01 expansion module.

4.1 Bus termination

The necessary bus terminator at the physically first and last node can alternatively be activated via the two DIP switches **S1** and **S2** on the EM-ENC-01 expansion module.

- Either set **S1** to ON and **S2** to OFF for a regular passive termination.
- or set **S1 and S2** to ON for an active termination. This results in an improved edge shape of the CAN signals, which causes an improvement of the signal shapes, in particular in extended systems.

Note: Switch **S3** is used to configure the analog input (see chapter "Analog input EM-S1INA").
Switch **S4** is used to configure a termination resistor of 150 Ω for the speed sensor input EM-ENC (see chapter „Speed Sensor input EM-ENC“).

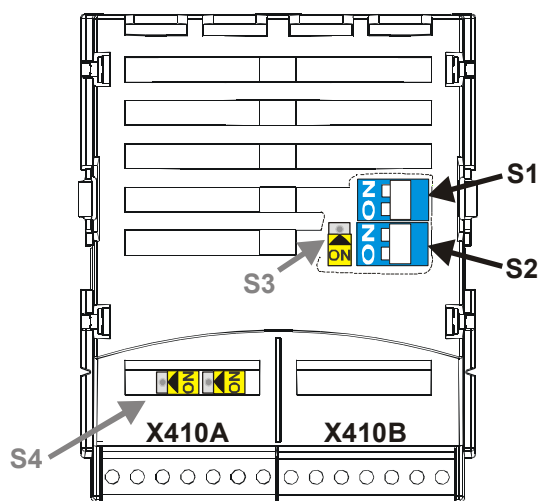

Attention! The factory setting for the bus termination is OFF.

The active termination via the DIP switches **S1** and **S2** may only be activated in **one** expansion module. The other bus termination must be passive.

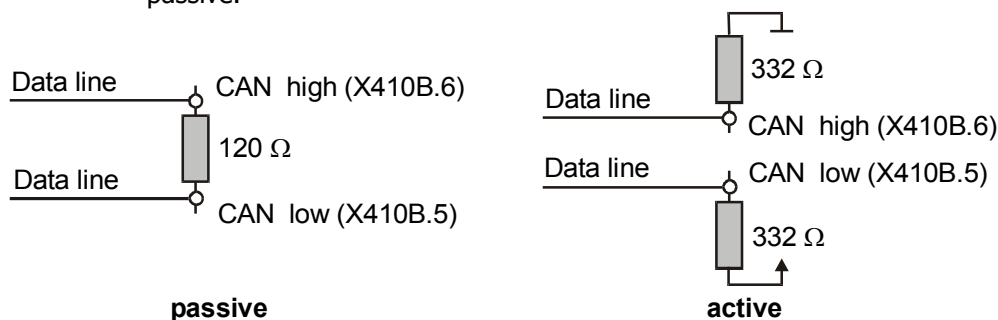

4.2 Cables

For the bus line, use twisted a cable with harness shield (**no foil shield**).

Attention! The control and communication lines are to be laid physically separate from the power lines. The harness screen of the data lines is to be connected to ground (PE) on both sides on a large area and with good conductivity.

4.3 Socket X410B

The system bus is connected via the terminals **5**, **6** and **7** of the plug **X410B** on the EM-ENC-01 expansion module.

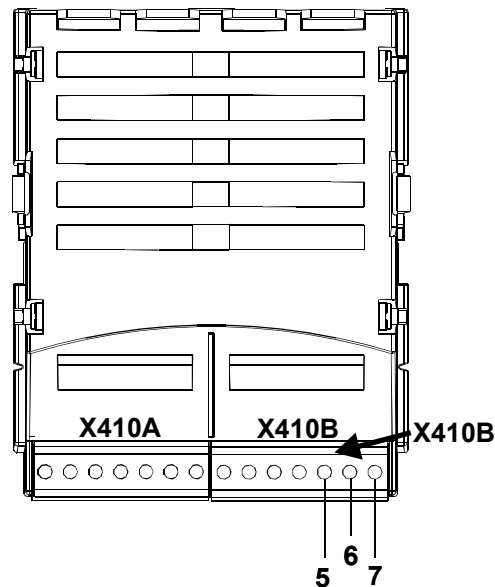

| Socket X410B | | |
|----------------------|--------------|-----------------------|
| Terminal | Input/Output | Description |
| (5) : X410B.5 | CAN-Low | CAN-Low (System bus) |
| (6) : X410B.6 | CAN-High | CAN-High (System bus) |
| (7) : X410B.7 | GND | CAN-GND (System bus) |

4.4 Baud rate setting/line length

The setting of the baud rate must be identical in all nodes on the system bus. The maximum possible baud rate is based on the necessary overall line length of the system bus. The baud rate is set via the parameter *Baud-Rate 903* and thus defines the possible line length.

| Operation mode | Function | max. line length |
|----------------|------------------------------|------------------|
| 3 - 50 kBaud | Transmission rate 50 kBaud | 1000 meters |
| 4 - 100 kBaud | Transmission rate 100 kBaud | 800 meters |
| 5 - 125 kBaud | Transmission rate 125 kBaud | 500 meters |
| 6 - 250 kBaud | Transmission rate 250 kBaud | 250 meters |
| 7 - 500 kBaud | Transmission rate 500 kBaud | 100 meters |
| 8 - 1000 kBaud | Transmission rate 1000 kBaud | 25 meters |

A baud rate under 50 kBaud, as is defined according to CANopen, is not sensible for the system bus as the data throughput is too low.

The maximum line lengths stated are guidelines. If they are made complete use of, a calculation of the admissible length is to be done on the basis of the line parameters and the bus driver (PCA82C250T).

4.5 Setting node address

A maximum of 63 slaves or frequency inverters with system bus can be operated on the system bus. Each frequency inverter is given a node ID, which may only exist once in the system, for its unambiguous identification. The setting of the system bus node ID is done via the parameter *Node-ID 900*.

| Parameter | | Setting | | |
|-----------|-------------|---------|------|-----------------|
| No. | Description | min. | max. | Factory setting |
| 900 | Node-ID | -1 | 63 | -1 |

Thus, the system bus possesses a maximum number of 63 nodes (Network nodes), plus one frequency inverter as a master.

Note: With the factory setting of parameter *Node-ID 900* = -1, the system bus is deactivated for this frequency inverter.
If the *Node-ID 900* = 0 is set, the frequency inverter is defined as a master. Only one frequency inverter on the system bus may be defined as a master.

4.6 Functional overview

To start with, the system bus produces the physical connection between the frequency inverters. Logical communication channels are produced via this physical medium. These channels are defined via the identifiers. As CAN does not possess a node-oriented, but a message-oriented addressing via the identifiers, the logical channels can be displayed via it.

In the basic state (factory setting) the identifiers are set according to the Predefined Connection Set of CANopen. These settings are aimed at one master serving all the channels. In order to be able to build up process data movement via the PDO channels between individual or a number of inverters (transverse movement), the setting of the identifiers in the nodes has to be adapted.

Note: For understanding, it is important to observe that the data exchange is done message-oriented. A frequency inverter can transmit and receive a number of messages, identified via various identifiers.

As a special feature, the properties of the CAN bus mean that the messages transmitted by one node can be received by a number of nodes simultaneously. The error monitoring methods of the CAN bus result in the message being rejected by all recipients and automatically transmitted again if there is a faulty reception in one receiver.

4.7 Network management

The network management controls the start of all the nodes on the system bus. Nodes can be started or stopped individually or together. For node recognition in a CAL or CANopen system, the slaves on the system bus generate a starting telegram (boot-up report).

In the event of a fault the slaves automatically transmit a fault report (emergency message).

For the functions of the network management, the methods and NMT telegrams (network management telegrams) defined according to CANopen (CiA DS 301) are used.

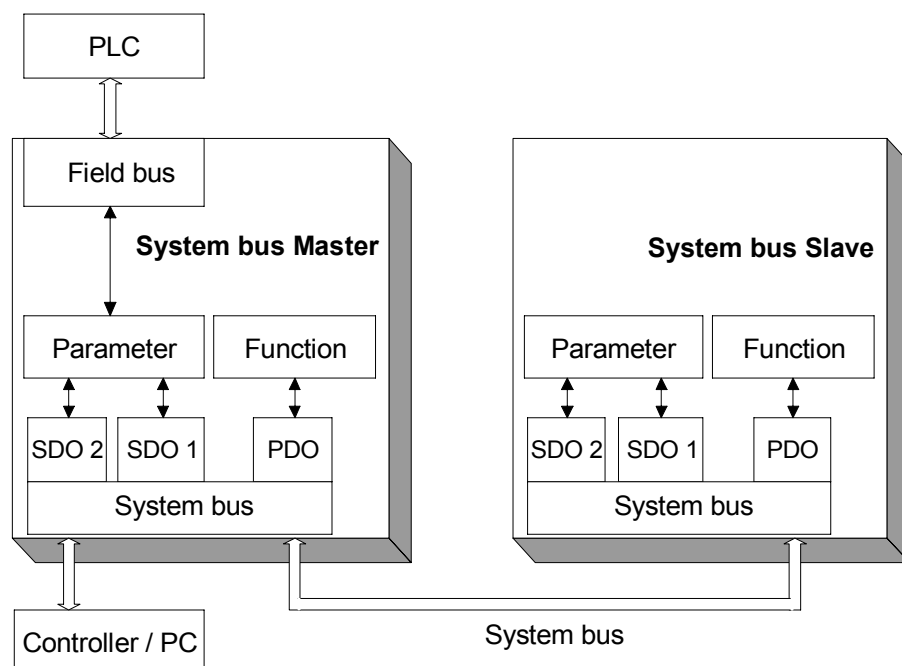

4.7.1 SDO channels (parameter data)

Each frequency inverter possesses two SDO channels for the exchange of parameter data. In a slave device, these are two server SDO's, in a device defined as a master a client SDO and a server SDO. Attention must be paid to the fact that only one master for each SDO channel may exist in a system.

Note: Only one master can initiate by the system bus an exchange of data via its client SDO.

The identifier assignment for the SDO channels (Rx/Tx) is done according to the Predefined Connection Set.

This assignment can be amended by parameterization, in order to solve identifier conflicts in a larger system in which further devices are on the CAN bus alongside the frequency inverters.

Attention! If a system in which a frequency inverter works as a master is produced, the identifier allocations for the SDO channel may not be altered. In this way, an addressing of individual nodes via the field bus/system bus path of the master frequency inverter is possible.

Parameters are read/written via the SDO channels. With the limitation to the SDO Segment Protocol Expedited, which minimizes the handling needed for the parameter exchange, the transmittable data are limited to the uint / int / long types. This permits complete parameterization of the frequency inverters via the system bus, as all the settings and practically all the actual values are displayed via these data types.

4.7.2 PDO channels (process data)

Each frequency inverter possesses three PDO channels (Rx/Tx) for the exchange of process data.

The identifier assignment for the PDO channel (Rx/Tx) is done by default according to the Predefined Connection Set. This assignment corresponds to an alignment to a central master control.

In order to produce the logical channels between the devices (transverse movement) on the system bus, the amendment of the PDO identifiers for Rx/Tx is necessary.

Each PDO channel can be operated with time or SYNC control. In this way, the operation behavior can be set for each PDO channel:

The setting of the operation mode is done via the following parameters:

TxPDO1 Function 930, TxPDO2 Function 932 und TxPDO3 Function 934

RxPDO1 Function 936, RxPDO2 Function 937 und RxPDO3 Function 938

| Operation mode | Function |
|--------------------|---|
| 0 -deactivated | no exchange of data via the PDO channel (Rx and/or Tx) |
| 1 -time-controlled | Tx-PDO's cyclically transmit according to the time specification Rx-PDO's are read in with $T_a = 1 \text{ ms}$ and forward the data received to the application |
| 2 -SYNC controlled | Tx-PDO's transmit the data from the application that are then current after the arrival of the SYNC telegram. Rx-PDO's forward the last data received to the application after the arrival of the SYNC telegram. |

For synchronous PDO's, the master (PC, PLC or frequency inverter) generates the SYNC telegram. The identifier assignment for the SYNC telegram is done by default according to the Predefined Connection Set. This assignment can be altered by parameterization.

4.8 Master functionality

An external control or a frequency inverter defined as a master (node ID = 0) can be used as a master. The fundamental tasks of the master are controlling the start of the network (boot-up sequence), generating the SYNC telegram and evaluating the emergency messages of the slaves.

Further, there can be access to the parameterization of all the frequency inverters on the system bus by means of a field bus connection via the client SDO of the master frequency inverter.

4.8.1 Control boot-up sequence, network management

The Minimum Capability Boot-Up method defined according to CANopen is used for the state control of the nodes (nodes).

This method knows the pre-operational, operational and stopped states.

After the initialization phase, all the nodes are in the pre-operational state. The system bus master transmits the NMT command **Start-Remote-Node**. With this command, individual nodes or all the nodes can be started together. A frequency inverter defined as a master starts **all** the nodes with **one** command. After receipt of the Start Remote Node command, the nodes change into the Operational state. From this time on, process data exchange via the PDO channels is activated.

A master in the form of a PLC/PC can start the nodes on the system bus individually and also stop them again.

As the slaves on the system bus need different lengths of time to conclude their initialization phases (especially if external components exist alongside the frequency inverters), an adjustable delay for the change to Operational is necessary. The setting is done in a frequency inverter defined as a system bus master via *Boot-Up Delay 904*.

| Parameter | | Setting | | |
|-----------|---------------|---------|----------|-----------------|
| No. | Description | Min. | Max. | Factory setting |
| 904 | Boot-Up Delay | 3500 ms | 50000 ms | 3500 ms |

Properties of the states:

| State | Properties |
|-----------------|--|
| Pre-Operational | Parameterization via SDO channel possible Exchange of process data via PDO channel not possible |
| Operational | Parameterization via SDO channel possible Exchange of process data via PDO channel possible |
| Stopped | Parameterization via SDO channel not possible Exchange of process data via PDO channel not possible |

Note: Start-Remote-Node is cyclically transmitted with the set delay time by a frequency inverter defined as a system bus master, in order to put slaves added with a delay or temporarily separated from the network back into the operational state.

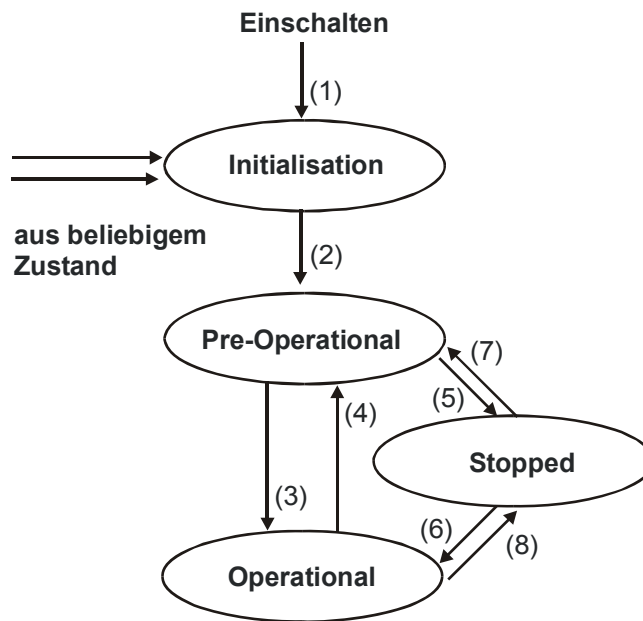

After Power On and the initialization, the slaves are in the Pre-Operational state. The transition (2) is automatic. The system bus master (frequency inverter or PLC/PC) triggers the transition (3) to Operational state. The transitions are controlled via NMT telegrams.

The identifier used for the NMT telegrams is "0" and may only be used by the system bus master for NMT telegrams. The telegram contains two data bytes.

| Byte 0 | Byte 1 |
|------------------------|---------|
| CS (Command Specifier) | Node-ID |

Identifier = 0

With the statement of the node ID $\neq 0$, the NMT command acts on the node selected via the node ID. If node ID = 0, **all** the nodes are addressed. If Node-ID = 0, **all** nodes are addressed.

| Transition | Command | Command Specifier |
|------------|-----------------------|-------------------|
| (3) , (6) | Start Remote Node | 1 |
| (4) , (7) | Enter Pre-Operational | 128 |
| (5) , (8) | Stop Remote Node | 2 |
| - | Reset Node | 129 |
| - | Reset Communication | 130 |

Note: A frequency inverter defined as a system bus master only transmits the command "Start Remote Node" with node ID = 0 (for all nodes). Transmission of the command is done after completion of the initialization phase and the time delay *Boot-Up Delay* **904** following it.

4.8.2 SYNC telegram, generation

If synchronous PDO's have been created on the system bus, the master must send the SYNC telegram cyclically. If a frequency inverter has been defined as a system bus master, the latter must generate the SYNC telegram. The interval for the SYNC telegram of a frequency inverter defined as the system bus master is adjustable. The SYNC telegram is a telegram without data.

The default identifier = 128 according to the Predefined Connection Set.

If a PC or PLC is used as a master, the identifier of the SYNC telegrams can be adapted by parameterization on the frequency inverter. The identifier of the SYNC telegram must be set identically in all nodes on the system bus.

The setting of the identifier of the SYNC telegram is done via the parameter *SYNC-Identifier* **918**.

| Parameter | | Setting | | |
|-----------|-----------------|---------|------|-------------|
| No. | Description | Min. | Max. | Fact. sett. |
| 918 | SYNC-Identifier | 0 | 2047 | 0 |

The setting "0" results in identifier assignment according to the Predefined Connection Set.

Attention! The identifier range 129...191 may not be used as the emergency telegrams can be found there.

The temporal cycle for the SYNC is set on a frequency inverter defined as a system bus master via the parameter *SYNC-Time* **919**.

Note: A setting of 0 ms for the parameter *SYNC-Time* **919** means "no SYNC telegram".

4.8.3 Emergency message, reaction

If a slave on the system bus suffers a fault, it transmits the emergency telegram. The emergency telegram marks the node ID for the identification of the failed node via its identifier and the existing fault message via its data contents (8 bytes).

After a fault has been acknowledged on the slave, the latter again transmits an emergency telegram with the data content zero.

The emergency telegram has the identifier 128 + node ID (= 129 ... 191)

The system bus master evaluates the emergency telegrams of the slaves. Its reaction to an emergency telegram can be set with *Emergency Reaction* **989**.

| Operation mode | Function |
|----------------|--|
| 0 -Error | The system bus master receives the emergency telegram and switches-off |
| 1 -No Error | The Emergency Telegram is displayed as a warning |

Operation mode - parameter 989 = 0 – Error

Behavior of the system bus master in *Emergency Reaction* **989** = 0 / Error:

As soon as the system bus master receives an emergency telegram, it also switches to failure mode and reports the failed node on the basis of its ID via the kind of error. Only the node is reported, not the cause of the error.

The fault message on the system bus master via *Current error* **260** is **21nn** with **nn = node ID** (hexadecimal) of the slave in which a fault switch-off exists.

In addition, the system bus master reports the warning Sysbus (0x2000) via the parameter *Warnings* **270** Bit 13.

If a fault switch-off occurs on a number of slaves, the first slave to transmit its emergency telegram is displayed on the system bus master.

Operation mode - parameter 989 = 1 – No Error

Behavior of system bus master in the case of *Emergency Reaction* **989** = 1 / No Error:

As soon as the system bus master receives an emergency telegram, it reports the warning Sysbus (0x2000) via the parameter *Warnings* **270** Bit 13.

Note: In both cases, the Boolean variable SysbusEmergency with source number 730 is set to TRUE in the system bus master. It can be used in the system bus master and (in transmission via a TxPDO) in the slaves for a defined shutdown.

SysbusEmergency is also set if the system bus master breaks down.

Resetting of SysbusEmergency is done with the fault acknowledgment.

4.8.4 Client SDO (system bus master)

Each node on the system bus can be addressed via the SDO channels. In this way, each node can be addressed and parameterized by one master via its client SDO1. All the parameters of the data types uint/int/long are accessible. String parameters can **not** be processed. If a frequency inverter has been defined as a system bus master, each node on the system bus in this frequency inverter can be addressed by means of a field bus connection (RS232, RS485, Profibus-DP) via its client SDO1.

Attention! The second SDO channel SDO2 of the frequency inverters is planned for the parameterization of the frequency inverters via a visualization tool on the system bus.

The service used is SDO Segment Protocol Expedited according to CANopen. A frequency inverter defined as a system bus master automatically generates the correct telegrams. If the SDO channel is operated via a PLC/PC on the system bus, the telegrams must be generated according to the specification.

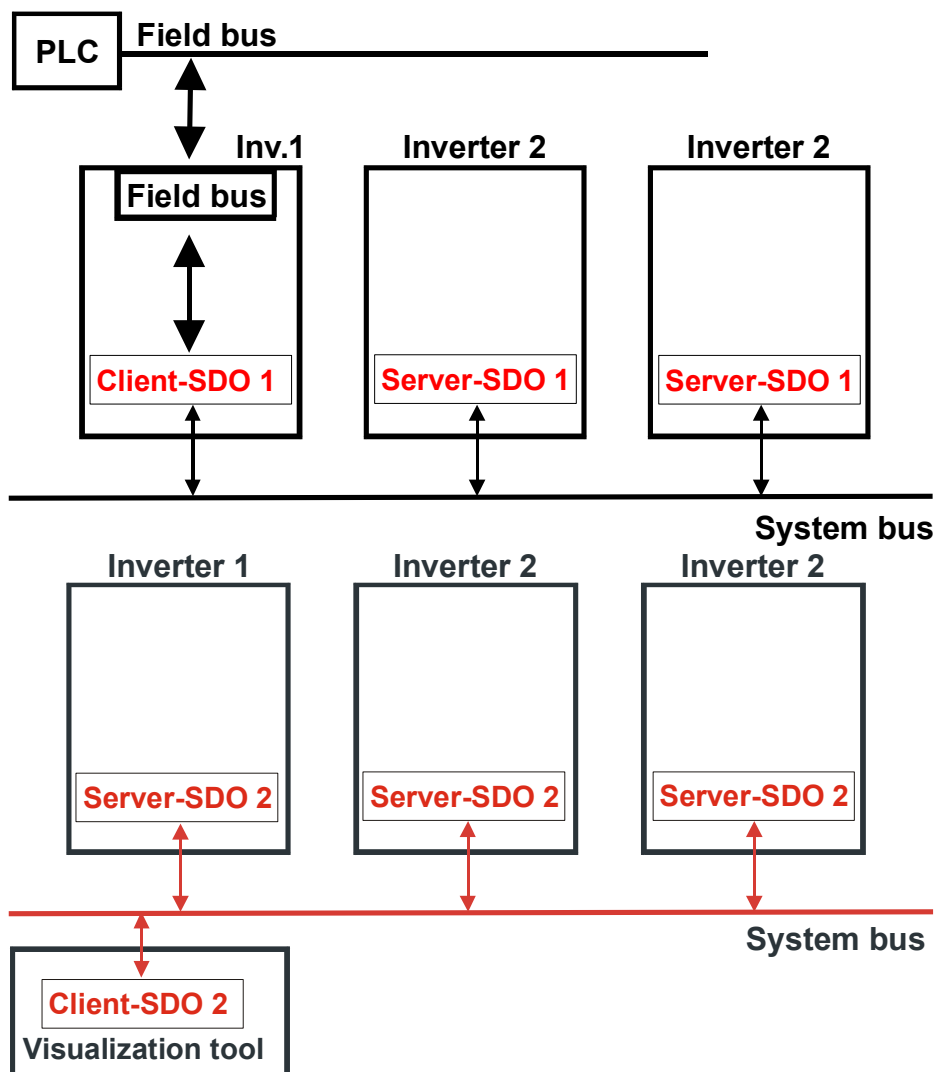

4.9 Slave functionality

4.9.1 Implement boot-up sequence, network management

4.9.1.1 Boot-up message

After the initialization, each slave on the system bus transmits its boot-up message (heartbeat message).

Note: The boot-up telegram has the identifier 1792 + node ID and a data byte with contents = 0x00.

This telegram is of importance if a PLC/PC with CANopen functionality is used as a master. The frequency inverter defined as a system bus master does **not** evaluate the boot-up message.

4.9.1.2 Status control

The identifier used for the NMT telegrams is "0" and may only be used by the system bus master for NMT telegrams. The telegram contains two data bytes.

| Byte 0 | Byte 1 |
|------------------------|---------|
| CS (Command Specifier) | Node-ID |

Identifier = 0

With the statement of the node ID $\neq 0$, the NMT command acts on the node selected via the node ID. If node ID = 0, **all** the nodes are addressed. If Node-ID = 0, **all** nodes are addressed.

| Transition | Command | Command Specifier |
|------------|-----------------------|-------------------|
| (3),(6) | Start Remote Node | 1 |
| (4),(7) | Enter Pre-Operational | 128 |
| (5),(8) | Stop Remote Node | 2 |
| - | Reset Node | 129 |
| - | Reset Communication | 130 |

Attention! The reset node and reset communication command specified according to DS 301 lead to a change to Pre-Operational via Initialization in the frequency inverters. There is a new boot-up message.

After a slave has received the command "Start Remote Node", it activates the PDO channels and is ready for the exchange of process data.

4.9.2 Process SYNC telegram

If synchronous PDO's have been created in a frequency inverter, their processing is synchronized with the SYNC telegram. The SYNC telegram is generated by the system bus master and is a telegram without data.

The identifier is 128 according to the Predefined Connection Set.

If a PC or PLC is used as a master, the identifier of the SYNC telegrams can be adapted by parameterization on the frequency inverter. The identifier of the SYNC telegram must be set identically in all nodes on the system bus.

Attention! The identifier range 129 ... 191 may not be used as the emergency telegrams can be found there.

The setting of the identifier of the SYNC telegram is done via the parameter *SYNC-Identifier* **918**.

| Parameter | | Setting | | |
|-----------|-----------------|---------|------|-----------------|
| No. | Description | Min. | Max. | Factory setting |
| 918 | SYNC-Identifier | 0 | 2047 | 0 |

The setting "0" results in identifier assignment according to the Predefined Connection Set.

The data of the Rx-PDO's are forwarded to the application after the arrival of the SYNC telegram. At the same time, the transmission of the Tx-PDO's with the currently available data from the application is triggered.

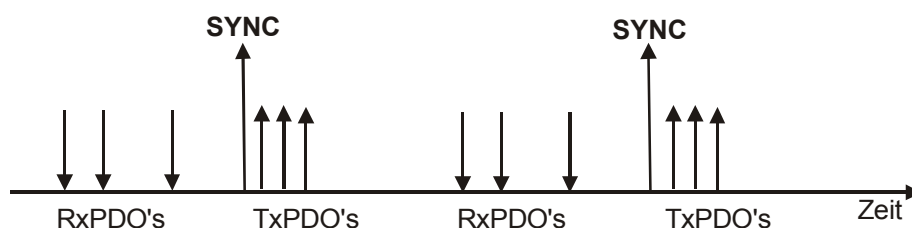

This method enables pre-occupancy of set points in the system bus nodes and a synchronous / parallel take-over of the data.

4.9.3 Emergency message, fault switch-off

As soon as a fault switch-off occurs in a slave frequency inverter, the emergency telegram is transmitted. The emergency telegram marks the node ID for the identification of the failed node via its identifier and the existing fault message via its data contents (8 bytes).

The emergency telegram has the identifier 128 + node ID.

After a fault acknowledgment, another emergency telegram is transmitted, with the data content (Byte 0 ...7) being set to zero this time. This identifies the node's repeated readiness for operation. If a further fault occurs subsequently, it is transmitted in a new emergency telegram.

The acknowledgment sequence is based on the definitions according to CANopen.

Data contents of the emergency telegram:

Emergency telegram

| Byte | Value | Meaning |
|------|-------|--------------------------------|
| 0 | 0x00 | low-byte Error-Code |
| 1 | 0x10 | high-byte Error-Code |
| 2 | 0x80 | Error-Register |
| 3 | 0x00 | - |
| 4 | 0x00 | - |
| 5 | 0x00 | - |
| 6 | 0xnn | internal Error-Code, low-byte |
| 7 | 0xmm | internal Error-Code, high-byte |

Bytes 0, 1 and 2 are firmly defined and compatible with CANopen.
Bytes 6/7 contain the product specific VECTRON error code.

Error-Code = 0x1000 = general error
Error-Register = 0x80 = manufacturer-specific error

The explanation and description of the product-specific VECTRON error code can be found in the annex "Error messages".

4.9.4 Server SDO1/SDO2

The communication channel for the exchange of parameter data is the SDO channel. Communication works according to the client/server model. The server is the node holding the data (here the frequency inverter), the client the node requesting or wanting to alter the data (PLC, PC or frequency inverter as system bus master).

For the frequency inverter, two server SDO channels have been implemented. The first SDO channel **SDO1** is used for the parameterization of the PLC/PC as a master or frequency inverter with field bus connection as a system bus master. The second SDO channel **SDO2** is reserved for a visualization tool for parameterization. An exchange of data can only be implemented by the master via a client SDO.

The SDO channels are stipulated for the server SDO's via identifiers according to the Predefined Connection Set to CANopen. As CANopen only provides for and defines one SDO channel in the Predefined Connection Set, the second SDO channel can be deactivated.

In addition, the number of system bus nodes and the adjustable node ID are limited to 63.

Identifier assignment according to the Predefined Connection Set:

Identifier Rx-SDO = 1536 + Node-ID (Node-ID = 1 ... 127, Identifier = 1537 ... 1663)

Identifier Tx-SDO = 1408 + Node-ID (Node-ID = 1 ... 127, Identifier = 1409 ... 1535)

Identifier assignment for SDO1/SDO2 compatible with the Predefined Connection Set:

Identifier Rx-SDO1 = 1536 + Node-ID (Node-ID = 1 ... 63, Identifier = 1537 ... 1599)

Identifier Tx-SDO1 = 1408 + Node-ID (Node-ID = 1 ... 63, Identifier = 1409 ... 1471)

Identifier Rx-SDO2 = 1600 + Node-ID (Node-ID = 0 ... 63, Identifier = 1600 ... 1663)

Identifier Tx-SDO2 = 1472 + Node-ID (Node-ID = 0 ... 63, Identifier = 1472 ... 1535)

This corresponds to the factory settings of the frequency inverters for the SDO's. The node ID = 0 for SDO2 is the system bus master.

Attention! The SDO2 must be deactivated in a CANopen system in order not to generate any compatibility problems.

If a frequency inverter has been defined as the system bus master, the above settings for the SDO1 must be maintained in all the frequency inverters. In this way, access to the parameterization of the frequency inverters via a field bus connection on the master frequency inverter is possible.

The client SDO1 in the master frequency inverter addresses the server SDO1 of the slaves via the above identifiers.

Attention! The identifiers for a visualization tool on the second SDO channel SDO2 cannot be changed.

If a PC or a PLC is used as a master, the identifiers of the **Rx/Tx-SDO1** can be adapted by parameterization on the frequency inverter.

Attention! In free assignment of the identifiers, there may not be any double occupancy!

The identifier range 129...191 may not be used as the emergency telegrams can be found there.

The setting of the identifiers of the RxSDO1 is done via the parameter *RxSDO1-Identifier* **921**.

| Parameter | | Setting | | |
|-----------|-------------------|---------|------|-------------|
| No. | Description | Min. | Max. | Fact. sett. |
| 921 | RxSDO1-Identifier | 0 | 2047 | 0 |

The setting of the identifiers of the TxSDO1 is done via parameter number **922**.

| Parameter | | Setting | | |
|-----------|-------------------|---------|------|-------------|
| No. | Description | Min. | Max. | Fact. sett. |
| 922 | TxSDO1-Identifier | 0 | 2047 | 0 |

The setting "0" results in identifier assignment according to the Predefined Connection Set.

The second SDO channel can be deactivated via the *SDO2 Set Active* **923**.

| Operation mode | Function |
|---------------------|--|
| 0 -SDO2 deactivated | Communication channel deactivated |
| 1 -SDO2 activated | Communication channel activated for the visualization tool |

The identifier assignment for the second SDO channel is always to the specification:

Identifier Rx-SDO2 = 1600 + Node-ID
 Identifier Tx-SDO2 = 1472 + Node-ID

Note: In this way, firm identifiers via which communication takes place are available for the visualization tool.

4.10 Communication channels, SDO1/SDO2

4.10.1 SDO telegrams (SDO1/SDO2)

The service used for the exchange of parameter data is **SDO Segment Protocol Expedited**. The data (type uint, int, long) are exchanged in a telegram.

Access to the parameters in the frequency inverters with a statement of parameter number and data set is displayed via the addressing defined for object access pursuant to the specifications of CANopen via Index/Sub-Index.
Index = parameter number / Sub index = data set.

The data to be transmitted have a length of 2 bytes for uint/int and 4 bytes for long. As standardization and simplification, 4 bytes are always transmitted.

The data are on bytes 4...7 of the SDO telegram.

- uint/int variables are transmitted in bytes 4 and 5 with bytes 6 und 7 = 0.
- long variables are transmitted in bytes 4...7.

Writing parameters:

Client → Server SDO Download (expedited)

| 0 | 1 | 2 | 3 | 4 | 5 | 6 | 7 |
|-------------|------------------|-----|----------|------|-----|------|------|
| Ctrl. byte | Parameter number | | Data set | Data | | | |
| 0x22 | LSB | MSB | 0xnn | LSB | | | MSB |
| uint/int | | | | LSB | MSB | 0x00 | 0x00 |
| long | | | | LSB | ... | ... | MSB |

Server → Client Download Response → Writing process free of errors

| 0 | 1 | 2 | 3 | 4 | 5 | 6 | 7 |
|-------------|------------------|-----|----------|------|---|---|---|
| Ctrl. byte | Parameter number | | Data set | Data | | | |
| 0x60 | LSB | MSB | 0xnn | 0 | | | |

Server → Client Abort SDO Transfer → Writing process faulty

| 0 | 1 | 2 | 3 | 4 | 5 | 6 | 7 |
|-------------|------------------|-----|----------|------|---|---|---|
| Ctrl. byte | Parameter number | | Data set | Data | | | |
| 0x80 | LSB | MSB | 0xnn | Code | 0 | 0 | 0 |

The error code is stated in byte 4 in a faulty reading process. (see Table, failure codes).

Attention! Control byte 0x22 for the identification "SDO Download expedited" does not consider the bits "s" (data size indicated) and "n" (number of bytes not containing data). If set, they are ignored. The user is responsible for the number of bytes matching the type of data.

Reading parameters:

Client → Server SDO Upload (expedited)

| | | | | | | | |
|-------------|------------------|----------|----------|----------|----------|----------|----------|
| 0 | 1 | 2 | 3 | 4 | 5 | 6 | 7 |
| Ctrl. byte | Parameter number | | Data set | Data | | | |
| 0x40 | LSB | MSB | 0xnn | 0 | | | |

Server → Client Upload Response → Reading process free of errors

| | | | | | | | |
|-------------|------------------|----------|----------|----------|----------|----------|----------|
| 0 | 1 | 2 | 3 | 4 | 5 | 6 | 7 |
| Ctrl. byte | Parameter number | | Data set | Data | | | |
| 0x42 | LSB | MSB | 0xnn | LSB | | | MSB |
| uint/int | | | | LSB | MSB | 0x00 | 0x00 |
| long | | | | LSB | ... | ... | MSB |

Server → Client Abort SDO Transfer → Reading process faulty

| | | | | | | | |
|-------------|------------------|----------|----------|----------|----------|----------|----------|
| 0 | 1 | 2 | 3 | 4 | 5 | 6 | 7 |
| Ctrl. byte | Parameter number | | Data set | Data | | | |
| 0x80 | LSB | MSB | 0xnn | Code | 0 | 0 | 0 |

The error code is stated in byte 4 in a faulty reading process.
(see Table, failure codes).

failure codes

| Code | Description |
|------|---|
| 1 | inadmissible parameter figure |
| 2 | inadmissible data set |
| 3 | parameter not readable |
| 4 | parameter not writable |
| 5 | reading error EEPROM |
| 6 | writing error EEPROM |
| 7 | checksum error EEPROM |
| 8 | parameter cannot be written during running drive |
| 9 | values of the data sets differ |
| 10 | parameter of wrong type |
| 11 | unknown parameter |
| 12 | BCC error in VECTRON bus protocol |
| 15 | unknown error |
| 20 | system bus node not available only in access via field bus connection |
| 21 | string parameter not admissible only in access via VECTRON bus protocol |

Errors marked in the table are generated by the field bus side, not in the Abort SDO Transfer of the system bus.

4.10.2 Communication via field bus connection (SDO1)

If a frequency inverter has been defined as the system bus master and equipped with a field bus interface, access to the parameterization of all the nodes in existence on the system bus is possible by means of this field bus interface via the first SDO channel (SDO1). An extension has been created in the protocol frame of the field buses for this purpose.

Attention! The prerequisite for this mechanism is that the identifier setting for the first SDO channel (SDO1) corresponds to the Predefined Connection Set. The parameter addressed must also be existent in the system bus master.

4.10.2.1 Profibus-DP

If an object with communication channel (PKW) is used in Profibus-DP, access to all the other nodes on the system bus can be done via it. The structure of the communication channel permits an additional addressing of a system bus node. This is done by the use of an unused byte in the communication channel.

Communication channel PKW

| 0 | 1 | 2 | 3 | 4 | 5 | 6 | 7 |
|--------|------------------|----------|--------------------|------|---|---|---|
| PKE | | Index | - | Data | | | |
| AK/SPM | Parameter number | Data set | Node-ID system bus | | | | |

Byte 3 is used to transmit the node ID of the required node on the system bus. If byte 3 = 0, the master inverter of the system bus is addressed. The display is binary (0...63).

4.10.2.2 RS232/RS485 with VECTRON bus protocol

In the VECTRON bus protocol, there is a byte in the telegram header that is always transmitted with 0 as a standard feature.

ENQUIRY

| 0 | 1 | 2 | 3 | 4 | 5 | 6 |
|---------|--------------------|----------|------------------|---|---|-----|
| Address | 0 | p | n | n | n | ENQ |
| | Node-ID system bus | Data set | Parameter number | | | |

SELECT

| 0 | 1 | 2 | 3 | 4 | | | |
|---------|-----|--------------------|----------|------------------|---|---|-----|
| Address | STX | 0 | p | n | n | n | ... |
| | | Node-ID System bus | Data set | Parameter number | | | |

Byte 1 in the enquiry and byte 2 in the select telegram are not defined and are used to transmit the node ID of the required node on the system bus. If this byte = 0, the master inverter of the system bus is addressed. The display is ASCII corresponding to the conventions for the display of the address in the VECTRON bus protocol.

Note: If there is an NAK fault message, the error is to be read out from the system bus master with node ID = 0 via parameter 11!

Display of node ID system bus in the VECTRON bus protocol:

System bus Node-ID

| System bus address | (ASCII-) character | HEX value | System bus address | (ASCII-) character | HEX value |
|--------------------|--------------------|-----------|--------------------|--------------------|-----------|
| 1 | A | 41 | 31 | | 5F |
| 2 | B | 42 | 32 | ` | 60 |
| 3 | C | 43 | 33 | a | 61 |
| 4 | D | 44 | 34 | b | 62 |
| 5 | E | 45 | 35 | c | 63 |
| 6 | F | 46 | 36 | d | 64 |
| 7 | G | 47 | 37 | e | 65 |
| 8 | H | 48 | 38 | f | 66 |
| 9 | I | 49 | 39 | g | 67 |
| 10 | J | 4A | 40 | h | 68 |
| 11 | K | 4B | 41 | i | 69 |
| 12 | L | 4C | 42 | j | 6A |
| 13 | M | 4D | 43 | k | 6B |
| 14 | N | 4E | 44 | l | 6C |
| 15 | O | 4F | 45 | m | 6D |
| 16 | P | 50 | 46 | n | 6E |
| 17 | Q | 51 | 47 | o | 6F |
| 18 | R | 52 | 48 | p | 70 |
| 19 | S | 53 | 49 | q | 71 |
| 20 | T | 54 | 50 | r | 72 |
| 21 | U | 55 | 51 | s | 73 |
| 22 | V | 56 | 52 | t | 74 |
| 23 | W | 57 | 53 | u | 75 |
| 24 | X | 58 | 54 | v | 76 |
| 25 | Y | 59 | 55 | w | 77 |
| 26 | Z | 5A | 56 | x | 78 |
| 27 | [| 5B | 57 | y | 79 |
| 28 | \ | 5C | 58 | z | 7A |
| 29 |] | 5D | 59 | { | 7B |
| 30 | ^ | 5E | 60 | | 7C |
| | | | 61 | } | 7D |
| | | | 62 | ~ | 7E |
| | | | 63 | □ | 7F |

4.11 Process data channels, PDO

4.11.1 Identifier assignment process data channel

The process channel for the exchange of process data under CANopen is the PDO channel. Up to three PDO channels with differing properties can be used in one device.

The PDO channels are defined via identifiers according to the Predefined Connection Set to CANopen:

Identifier 1. Rx-PDO = 512 + Node-ID
 Identifier 1. Tx-PDO = 384 + Node-ID

Identifier 2. Rx-PDO = 768 + Node-ID
 Identifier 2. Tx-PDO = 640 + Node-ID

Identifier 3. Rx-PDO = 1024 + Node-ID
 Identifier 3. Tx-PDO = 896 + Node-ID

This corresponds to the factory settings of the frequency inverters for the Rx/Tx-PDO's. This occupancy is aligned to an external master (PLC/PC) serving all the channels.

If the PDO channels are used for a connection of the frequency inverters amongst one another, the identifiers are to be set accordingly by parameterization.

Attention! In free assignment of identifiers, there may not be any double occupancy!

The identifier range 129...191 may not be used as the emergency telegrams can be found there.

Setting of the identifiers of the Rx/TxPDO's:

| Parameter | | Setting | | |
|-----------|-------------------|---------|------|-------------|
| No. | Description | Min. | Max. | Fact. sett. |
| 924 | RxPDO1 Identifier | 0 | 2047 | 0 |
| 925 | TxPDO1 Identifier | 0 | 2047 | 0 |
| 926 | RxPDO2 Identifier | 0 | 2047 | 0 |
| 927 | TxPDO2 Identifier | 0 | 2047 | 0 |
| 928 | RxPDO3 Identifier | 0 | 2047 | 0 |
| 929 | TxPDO3 Identifier | 0 | 2047 | 0 |

The setting "0" results in identifier assignment according to the Predefined Connection Set.

4.11.2 Operation modes process data channel

The transmit/receive behavior can be time controlled or controlled via a SYNC telegram. The behavior can be parameterized for each PDO channel.

Tx-PDO's can work time controlled or SYNC controlled. A time controlled TxPDO transmits its data at the interval of time set. A SYNC controlled TxPDO transmits its data after the arrival of a SYNC telegram.

RxPDO's in the time controlled setting forward the received data to the application immediately. If an RxPDO has been defined as SYNC controlled, its forwards its received data to the application after the arrival of a SYNC telegram.

Settings TxPDO1/2/3

| Parameter | | Setting | | |
|-----------|-------------|---------|----------|-------------|
| No. | Description | Min. | Max. | Fact. sett. |
| 931 | TxPDO1 Time | 1 ms | 50000 ms | 8 ms |
| 933 | TxPDO2 Time | 1 ms | 50000 ms | 8 ms |
| 935 | TxPDO3 Time | 1 ms | 50000 ms | 8 ms |

The setting of the operation mode is done via the following parameters:

TxPDO1 Function 930, TxPDO2 Function 932 und TxPDO3 Function 934

| Operation mode | Function |
|-----------------------|--|
| 0 -Not Active | No data are sent |
| 1 -Controlled by time | In the cycle of the adjusted time interval the data are sent |
| 2 -Controlled by SYNC | To arrival of a SYNC telegram the data are sent |

Settings RxPDO1/2/3

The setting of the operation mode is done via the following parameters:

RxPDO1 Function 936, RxPDO2 Function 937 und RxPDO3 Function 938

| Operation mode | Function |
|-----------------------|--|
| 0 -Controlled by time | The received data are passed on immediately |
| 1 -Controlled by SYNC | After arrival of a SYNC telegram the received data are passed on |

Note: In the "controlled by time" operation mode, there is a polling of the received data with the trigger cycle of $T_a = 1$ ms.

4.11.3 Timeout monitoring process data channel

Each frequency inverter monitors its received data for whether they are updated within a defined time window.

The monitoring is done onto the SYNC telegram and the RxPDO channels.

Monitoring SYNC / RxPDO's

| Parameter | | Setting | | |
|-----------|----------------|---------|----------|-------------|
| No. | Description | Min. | Max. | Fact. sett. |
| 939 | SYNC Timeout | 0 ms | 60000 ms | 0 ms |
| 941 | RxPDO1 Timeout | 0 ms | 60000 ms | 0 ms |
| 942 | RxPDO2 Timeout | 0 ms | 60000 ms | 0 ms |
| 945 | RxPDO3 Timeout | 0 ms | 60000 ms | 0 ms |

Setting 0 means no timeout monitoring.

Attention! There is only monitoring for the SYNC telegram if at least one RxPDO or one TxPDO channel is defined as SYNC controlled.

If a timeout period is exceeded, the frequency inverter switches to failure mode and reports one of the faults:

F2200 System bus Timeout SYNC

F2201 System bus Timeout RxPDO1

F2202 System bus Timeout RxPDO2

F2203 System bus Timeout RxPDO3

4.11.4 Communication relationships of the process data channel

Regardless of the process data to be transmitted, the communication relationships of the process data channels must be defined. The connection of PDO channels is done via the assignment of the identifiers. The identifiers of Rx-/Tx-PDO must match in each case.

There are two principal possibilities:

- **one** Rx-PDO to **one** Tx-PDO (one to one)
- connect **several** Rx-PDO's to **one** TxPDO (one to many)

This process is documented in a tabular form via a **communication relationship list**.

Example:

| Frequency inverter 1 | | Frequency inverter 2 | | Frequency inverter 3 | |
|----------------------|------------|----------------------|------------|----------------------|------------|
| PDO | Identifier | PDO | Identifier | PDO | Identifier |
| TxPDO1 | 385 | TxPDO1 | | TxPDO1 | |
| RxPDO1 | | RxPDO1 | 385 | RxPDO1 | 385 |
| TxPDO2 | 641 | TxPDO2 | | TxPDO2 | 642 |
| RxPDO2 | | RxPDO2 | 641 | RxPDO2 | |
| TxPDO3 | | TxPDO3 | | TxPDO3 | |
| RxPDO3 | | RxPDO3 | 642 | RxPDO3 | |

Attention! All the TxPDO's used must have differing identifiers!
The Identifier must be clear in the system bus network.

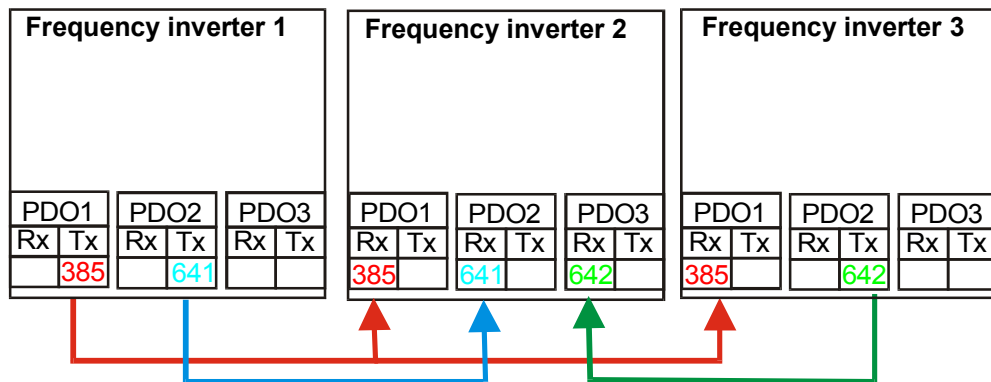

4.11.5 Virtual links

A PDO telegram contains 0 ...8 data bytes according to CANopen. A mapping for any kind of objects can be done in these data bytes.

For the system bus, the PDO telegrams are firmly defined with 8 data bytes. The mapping is not done via mapping parameters as with CANopen, but via the method of sources and links.

Each function provides its output data via a source. These sources are defined via source numbers. The input data of functions are defined via parameters. The link of a data input to a data output is done via the assignment of parameters to source numbers.

Example 1:

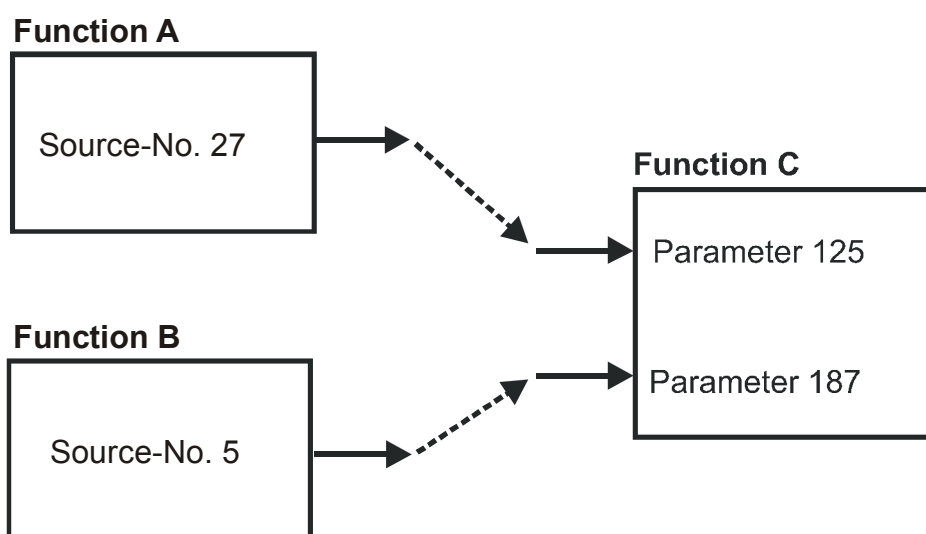

In example 1, the two inputs of function C are connected to the outputs of functions A and B. The parameterization for this connection is thus:

Function C

Parameter 125 = Source-No. 27
Parameter 187 = Source-No. 5

Example of a virtual link in the VPlus PC program:

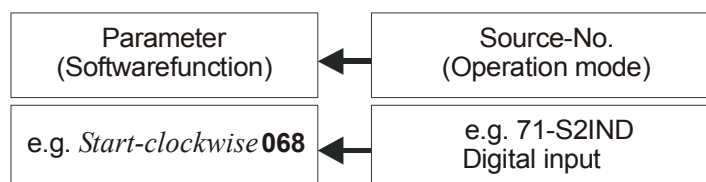

The assignment of the operation modes to the software functions available can be adapted to the application in question.

For the system bus, the input data of the TxPDO's are also displayed as input parameters and the output data of the RxPDO's as sources.

Example 2:

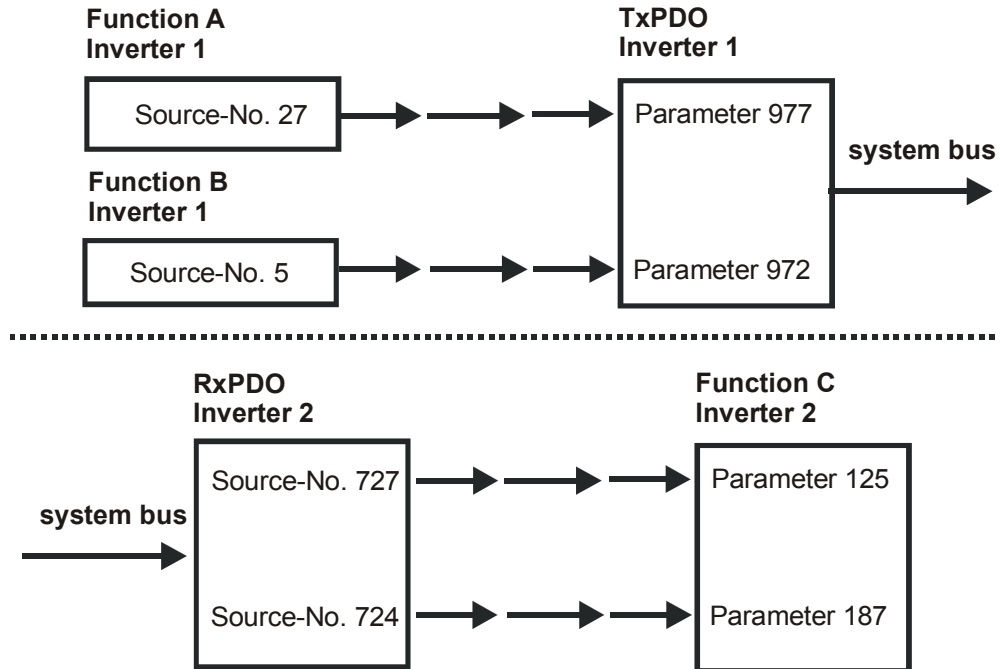

Example 2 displays the same situation as Example 1. But now, the functions A and B are in frequency inverter 1 and function C in frequency inverter 2. The connection is done via a TxPDO in frequency inverter 1 and a RxPDO in frequency inverter 2. Thus, the parameterization for this connection is:

Frequency inverter 1

- Parameter 977 = Source-No. 27
- Parameter 972 = Source-No. 5

Frequency inverter 2

- Parameter 125 = Source-No. 727
- Parameter 187 = Source-No. 724

As the links with the system used exceed the device limits, they are termed "virtual links".

The virtual links with the possible sources are related to the Rx/TxPDO channels. For this purpose, the eight bytes of the Rx-/TxPDO's are defined structured as inputs and sources. This exists for each of the three PDO channels.

Each transmit PDO and receive PDO can be occupied as follows:

4 Boolean variables

or

4 uint/int variables

or

2 long variables

or

a mixture paying attention to the eight bytes available

Assignment data type / number of bytes:

| Assignment | |
|------------|---------|
| Data type | Length |
| Boolean | 2 Bytes |
| uint/int | 2 Bytes |
| long | 4 Bytes |

4.11.5.1 Input parameters of the TxPDO's for data to be transmitted

The listed parameters can be used to stipulate the data that are to be transported there for each position in the TxPDO telegrams. The setting is done in such a way that a source number is entered for the required data in the parameters.

| TxPDO1 | P. No. | TxPDO1 | P. No. | TxPDO1 | P. No. |
|---------------|----------------------|---------------|-----------------------|---------------|---------------------|
| Byte | Boolean input | Byte | uint/int input | Byte | long input |
| 0 | 946 | 0 | 950 | 0 | 954 Long1 |
| 1 | Boolean1 | 1 | Word1 | 1 | |
| 2 | 947 | 2 | 951 | 2 | |
| 3 | Boolean2 | 3 | Word2 | 3 | 955 Long2 |
| 4 | 948 | 4 | 952 | 4 | |
| 5 | Boolean3 | 5 | Word3 | 5 | |
| 6 | 949 | 6 | 953 | 6 | |
| 7 | Boolean4 | 7 | Word4 | 7 | |

| TxPDO2 | P. No. | TxPDO2 | P. No. | TxPDO2 | P. No. |
|---------------|----------------------|---------------|-----------------------|---------------|---------------------|
| Byte | Boolean input | Byte | uint/int input | Byte | long input |
| 0 | 956 | 0 | 960 | 0 | 964 Long1 |
| 1 | Boolean1 | 1 | Word1 | 1 | |
| 2 | 957 | 2 | 961 | 2 | |
| 3 | Boolean2 | 3 | Word2 | 3 | 965 Long2 |
| 4 | 958 | 4 | 962 | 4 | |
| 5 | Boolean3 | 5 | Word3 | 5 | |
| 6 | 959 | 6 | 963 | 6 | |
| 7 | Boolean4 | 7 | Word4 | 7 | |

| TxPDO3 | P. No. | TxPDO3 | P. No. | TxPDO3 | P. No. |
|---------------|----------------------|---------------|-----------------------|---------------|---------------------|
| Byte | Boolean input | Byte | uint/int input | Byte | long input |
| 0 | 966 | 0 | 972 | 0 | 976 Long1 |
| 1 | Boolean1 | 1 | Word1 | 1 | |
| 2 | 967 | 2 | 973 | 2 | |
| 3 | Boolean2 | 3 | Word2 | 3 | 977 Long2 |
| 4 | 968 | 4 | 974 | 4 | |
| 5 | Boolean3 | 5 | Word3 | 5 | |
| 6 | 969 | 6 | 975 | 6 | |
| 7 | Boolean4 | 7 | Word4 | 7 | |

Note: Depending on the selected data information the percentages values are displayed via the uint/int inputs.

With this method, there are up to three possibilities for a meaning of the contents of the individual bytes. Each byte may only be used for one possibility.

To ensure this, the processing of the input links is derived from the setting. If an input link has been set to the fixed value of zero, it is **not** processed.

The settings for the fixed value zero are:

Source = 7 (FALSE) for Boolean variables
 Source = 9 (0) for uint, int, long variables

This is simultaneously the factory setting.

Examples Boolean source

| Boolean source | |
|----------------|--------------------------------|
| Source | Data |
| 6 | TRUE |
| 7 | FALSE |
| 70 | Contact input 1 |
| 71 | Contact input 2 |
| 72 | Contact input 3 |
| 161 | Running message |
| 163 | Nominal figure reached |
| 164 | Set frequency reached (P. 510) |

Examples uint/int source

| unit/int source | |
|-----------------|-------------------------------------|
| Source | Data |
| 9 | 0 |
| 63 | Reference percentage 1 |
| 64 | Reference percentage 2 |
| 52 | Percentage MFI1 |
| 133 | Output percentage ramp |
| 137 | Output reference percentage channel |
| 138 | Output actual percentage channel |
| 740 | Control word |
| 741 | State word |

Examples long source

| long source | |
|-------------|--|
| Source | Data |
| 9 | 0 |
| 0 | Output frequency ramp |
| 1 | Fixed frequency 1 |
| 5 | Reference line value |
| 62 | Output frequency reference value channel |
| 50 | Reference frequency MFI1 |

4.11.5.2 Source numbers of the RxPDO's for received data

Equivalent to the input links of the TxPDO's, the received data of the RxPDO's are displayed via sources or source numbers. The sources existing in this way can be used in the frequency inverter via the local input links for the data targets.

| RxPDO1 Byte | Source No. Boolean value | RxPDO1 Byte | Source No. uint/int value | RxPDO1 Byte | Source No. long- Value |
|----------------|--------------------------------|----------------|---------------------------------|----------------|------------------------------|
| 0 | 700 | 0 | 704 | 0 | 708 Long1 |
| 1 | Boolean1 | 1 | Word1 | 1 | |
| 2 | 701 | 2 | 705 | 2 | |
| 3 | Boolean2 | 3 | Word2 | 3 | 709 Long2 |
| 4 | 702 | 4 | 706 | 4 | |
| 5 | Boolean3 | 5 | Word3 | 5 | |
| 6 | 703 | 6 | 707 | 6 | |
| 7 | Boolean4 | 7 | Word4 | 7 | |

| RxPDO2 Byte | Source No. Boolean value | RxPDO2 Byte | Source No. uint/int value | RxPDO2 Byte | Source No. long value |
|----------------|--------------------------------|----------------|---------------------------------|----------------|-----------------------------|
| 0 | 710 | 0 | 714 | 0 | 718 Long1 |
| 1 | Boolean1 | 1 | Word1 | 1 | |
| 2 | 711 | 2 | 715 | 2 | |
| 3 | Boolean2 | 3 | Word2 | 3 | 719 Long2 |
| 4 | 712 | 4 | 716 | 4 | |
| 5 | Boolean3 | 5 | Word3 | 5 | |
| 6 | 713 | 6 | 717 | 6 | |
| 7 | Boolean4 | 7 | Word4 | 7 | |

| RxPDO3 Byte | Source No. Boolean value | RxPDO3 Byte | Source No. uint/int value | RxPDO3 Byte | Source No. long value |
|----------------|--------------------------------|----------------|---------------------------------|----------------|-----------------------------|
| 0 | 720 | 0 | 724 | 0 | 728 Long1 |
| 1 | Boolean1 | 1 | Word1 | 1 | |
| 2 | 721 | 2 | 725 | 2 | |
| 3 | Boolean2 | 3 | Word2 | 3 | 729 Long2 |
| 4 | 722 | 4 | 726 | 4 | |
| 5 | Boolean3 | 5 | Word3 | 5 | |
| 6 | 723 | 6 | 727 | 6 | |
| 7 | Boolean4 | 7 | Word4 | 7 | |

With this method, there are up to three possibilities for a meaning of the contents of the individual bytes. Each byte may only be used for one possibility.

Note: Depending on the selected data information the percentages values are displayed via the uint/int inputs.

4.11.5.3 Examples of virtual links

Example 1:

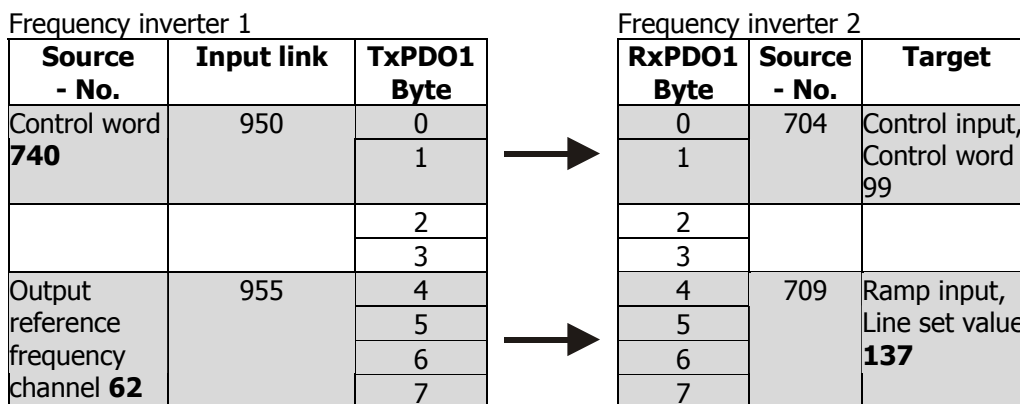

Parameter 950 = Source-No. 740
Parameter 955 = Source-No. 62

Parameter 99 = Source-No. 704
Parameter 137 = Source-No. 709

The control word of frequency inverter 1 is linked with the control word of frequency inverter 2. In this way, both frequency inverters can be operated synchronously via the remote control. The output of the reference value channel of frequency inverter 1 is laid onto the output of the ramp of frequency inverter 2. In this way, both frequency inverters have a joint source of reference values and are given reference values in the internal notation.

As an extension, a number of frequency inverters can also exist on the receive side (Rx), these then being supplied with data parallel and simultaneously.

The input link not used in the TxPDO1 of frequency inverter 1 is on ZERO and is thus not served.

Example 2:

Example of a virtual link with transmission via the system bus:

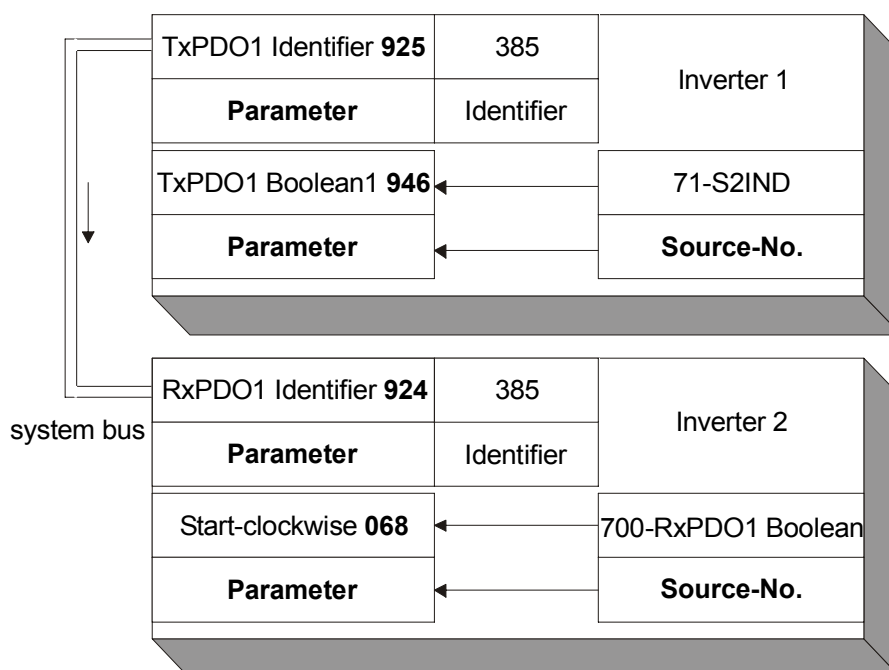

4.12 Control parameters

For the monitoring of the system bus and the display of the internal states, two control parameters are provided. There is a report of the system bus state and a report of the CAN state via two actual value parameters.

The parameter *Node-State* **978** gives information about the Pre-Operational, Operational, Stopped state. A PDO transfer is only possible in the Operational state. The state is controlled by the system bus master (PLC / PC / frequency inverter) via NMT telegrams.

The parameter *CAN-State* **979** gives information about the state of the physical layer. If there are transmission errors, the state changes from OKAY to WARNING until the cancellation of the communication with BUS-OFF. After BUS-OFF, the CAN controller is automatically re-initialized and the system bus started again.

Note: If the BUS-OFF state occurs, the frequency inverter breaks down with "**F2210 BUS-OFF**".

After Bus-OFF, the system bus in the frequency inverter is completely reinitialized. There is a new boot-up message from the node and an emergency telegram with the Bus-OFF message is transmitted. The change of state of the node to Operational is done by the Start-Remote-Node telegram cyclically sent by the system bus master.

Actual values of the system bus

| No. | Description | Display |
|-----|-------------|---|
| 978 | Node-State | 1 - Pre-Operational 2 - Operational 3 - Stopped |
| 979 | CAN-State | 1 - OKAY 2 - WARNING 3 - BUS-OFF |

4.13 Handling of the parameters of the system bus

As soon as the system bus expansion module EM-SYS exists in a frequency inverter, the actual value parameters for system state and bus state are activated and can be observed in the actual value menu **VAL** of the control unit KP500 or with the VPlus PC program in the menu **Actual values \ Systembus**.

Note: The actual value parameters are on control level 3 and are thus available for the user at any time.

All the setting parameters for the configuration of the system bus are not directly accessible for the user. For defined customer applications, pre-defined XPI files can be generated by VECTRON for the VPlus PC program, with which the necessary parameters are visible for the user. The application-relevant variables are then available in these XPI files.

Note: XPI files can be read in addition to the loaded parameter information of the frequency inverter into the VPlus PC program. In the menu of the software under the point Edit you find the command "Read in XPI file".

The method of working via an XPI file has its reasoning in the fact that deep interventions in the system are possible via the system bus and can lead to serious problems in the application with an untrained user. Via the XPI files, a user is given a selection list pre-defined by VECTRON.

Attention! The configuration of the necessary parameters for the system bus are accessible by a XPI file with the help of the VPlus PC program. The control unit KP500 does not support this functionality. If the expansion module system bus EM-SYS is installed additionally to a communication module for the field bus connection (CM-232, CM-485 or CM-PDP) in the frequency inverter, the parameterization can be made with the interface adapter KP232.

Experienced users have complete access to all the existing sources and possible input links with the XPI file of the active functions. The selection depends on the selected configuration and control procedure.

The display of the parameters when using the XPI file is according to the following structure:

| | |
|-------------------------|--|
| System bus | |
| Basic Settings | 900Node-ID 903Baud-Rate |
| Master Functions | 904Boot-Up Delay 919SYNC-Time |
| SYNC-Identifier | 918SYNC-Identifier |
| SDO1-Identifier | 921RxSDO1-Identifier 922TxSDO1-Identifier |
| SDO2 Set Active | 923SDO2 Set Active |
| PDO-Identifier | 924RxPDO1-Identifier 925TxPDO1-Identifier 926RxPDO2-Identifier 927TxPDO2-Identifier 928RxPDO3-Identifier 929TxPDO3-Identifier |

| | |
|-----------------------|--|
| TxPDO-Function | 930TxPDO1 Function 931TxPDO1 Time 932TxPDO2 Function 933TxPDO2 Time 934TxPDO3 Function 935TxPDO3 Time |
| RxPDO-Function | 936RxPDO1 Function 937RxPDO2 Function 938RxPDO3 Function |
| Timeout | 939SYNC Timeout 941RxPDO1 Timeout 942RxPDO2 Timeout 945RxPDO3 Timeout |
| TxPDO1 Objects | 946TxPDO1 Boolean1 947TxPDO1 Boolean2 948TxPDO1 Boolean3 949TxPDO1 Boolean4 950TxPDO1 Word1 951TxPDO1 Word2 952TxPDO1 Word3 953TxPDO1 Word4 954TxPDO1 Long1 955TxPDO1 Long2 |
| TxPDO2 Objects | 956TxPDO2 Boolean1 957TxPDO2 Boolean2 958TxPDO2 Boolean3 959TxPDO2 Boolean4 960TxPDO2 Word1 961TxPDO2 Word2 962TxPDO2 Word3 963TxPDO2 Word4 964TxPDO2 Long1 965TxPDO2 Long2 |
| TxPDO3 Objects | 966TxPDO3 Boolean1 967TxPDO3 Boolean2 968TxPDO3 Boolean3 969TxPDO3 Boolean4 972TxPDO3 Word1 973TxPDO3 Word2 974TxPDO3 Word3 975TxPDO3 Word4 976TxPDO3 Long1 977TxPDO3 Long2 |
| Actual values | |
| System bus | 978Node-State 979CAN-State |

4.14 Utilities

For the planning of the system bus according to the drive tasks in question, there are ancillaries in the form of tables.

The planning of the system bus is done in three steps:

1. Definition of the communication relationships
2. Production of the virtual links
3. Capacity planning of the system bus

The priority assignment of the identifiers is relevant for the definition of the communication relationships. Data that are to be transmitted with a higher priority must be given low identifiers. This results in the message with the higher priority being transmitted first with a simultaneous access of two nodes to the bus.

Note: The recommended identifier range for the communication relationships via the PDO channels is 385 ...

The identifiers below 385 are used for the NMT telegrams (boot-up sequence, SYNC telegram) and emergency message.

The identifiers above 1407 are used for the SDO channel for parameterization.

4.14.1 Definition of the communication relationships

The communication relationships are planned and documented with the help of the table. The table is available as a Microsoft Word document "kbl.doc" on the BONFIGLIOLI VECTRON product CD or upon request.

| | | | | |
|-----------------|-----------------|-----------------|-----------------|-----------------|
| Inverter: _____ | Inverter: _____ | Inverter: _____ | Inverter: _____ | Inverter: _____ |
| Node-ID: _____ | Node-ID: _____ | Node-ID: _____ | Node-ID: _____ | Node-ID: _____ |
| PDO | PDO | PDO | PDO | PDO |
| Identifier | Identifier | Identifier | Identifier | Identifier |
| TxPDO1 | TxPDO1 | TxPDO1 | TxPDO1 | TxPDO1 |
| RxPDO1 | RxPDO1 | RxPDO1 | RxPDO1 | RxPDO1 |
| TxPDO2 | TxPDO2 | TxPDO2 | TxPDO2 | TxPDO2 |
| RxPDO2 | RxPDO2 | RxPDO2 | RxPDO2 | RxPDO2 |
| TxPDO3 | TxPDO3 | TxPDO3 | TxPDO3 | TxPDO3 |
| RxPDO3 | RxPDO3 | RxPDO3 | RxPDO3 | RxPDO3 |

4.14.2 Production of the virtual links

The virtual links are planned and documented with the help of the table. The table is available as a Microsoft Word document "vvk.doc" on the BONFIGLIOLI VECTRON product CD or upon request.

| <p>Inverter: _____</p> <p>Node-ID: _____</p> <p>TxPDO-No.: _____</p> | <p>Identifier: _____ (Tx/RxPDO)</p> | | | | | | | | | | | | | | | | | | | | | | | | | | | | | | | | | | | | | | | | | | | | | | |
|--|---|--------------------------|------|--|---------|----------|------|--|--|--|--|--|--|--|--|--|--|--|--|--|--|--|--|--|----------------|--------------------------|--|--|---------|----------|------|--|--|--|--|--|--|--|--|--|--|--|--|--|--|--|--|
| <p>Inverter: _____</p> <p>Node-ID: _____</p> <p>RxPDO-No.: _____</p> | <p>Identifier: _____ (Tx/RxPDO)</p> | | | | | | | | | | | | | | | | | | | | | | | | | | | | | | | | | | | | | | | | | | | | | | |
|  | | | | | | | | | | | | | | | | | | | | | | | | | | | | | | | | | | | | | | | | | | | | | | | |
| <table border="1" style="width: 100%;"> <thead> <tr> <th rowspan="2">Source- No.</th> <th colspan="3">Input Link/Parameter-No.</th> </tr> <tr> <th>Boolean</th> <th>uint/int</th> <th>long</th> </tr> </thead> <tbody> <tr><td> </td><td> </td><td> </td><td> </td></tr> <tr><td> </td><td> </td><td> </td><td> </td></tr> <tr><td> </td><td> </td><td> </td><td> </td></tr> <tr><td> </td><td> </td><td> </td><td> </td></tr> </tbody> </table> | Source- No. | Input Link/Parameter-No. | | | Boolean | uint/int | long | | | | | | | | | | | | | | | | | <table border="1" style="width: 100%;"> <thead> <tr> <th rowspan="2">Source- No.</th> <th colspan="3">Input Link/Parameter-No.</th> </tr> <tr> <th>Boolean</th> <th>uint/int</th> <th>long</th> </tr> </thead> <tbody> <tr><td> </td><td> </td><td> </td><td> </td></tr> <tr><td> </td><td> </td><td> </td><td> </td></tr> <tr><td> </td><td> </td><td> </td><td> </td></tr> <tr><td> </td><td> </td><td> </td><td> </td></tr> </tbody> </table> | Source- No. | Input Link/Parameter-No. | | | Boolean | uint/int | long | | | | | | | | | | | | | | | | |
| Source- No. | | Input Link/Parameter-No. | | | | | | | | | | | | | | | | | | | | | | | | | | | | | | | | | | | | | | | | | | | | | |
| | Boolean | uint/int | long | | | | | | | | | | | | | | | | | | | | | | | | | | | | | | | | | | | | | | | | | | | | |
| | | | | | | | | | | | | | | | | | | | | | | | | | | | | | | | | | | | | | | | | | | | | | | | |
| | | | | | | | | | | | | | | | | | | | | | | | | | | | | | | | | | | | | | | | | | | | | | | | |
| | | | | | | | | | | | | | | | | | | | | | | | | | | | | | | | | | | | | | | | | | | | | | | | |
| | | | | | | | | | | | | | | | | | | | | | | | | | | | | | | | | | | | | | | | | | | | | | | | |
| Source- No. | Input Link/Parameter-No. | | | | | | | | | | | | | | | | | | | | | | | | | | | | | | | | | | | | | | | | | | | | | | |
| | Boolean | uint/int | long | | | | | | | | | | | | | | | | | | | | | | | | | | | | | | | | | | | | | | | | | | | | |
| | | | | | | | | | | | | | | | | | | | | | | | | | | | | | | | | | | | | | | | | | | | | | | | |
| | | | | | | | | | | | | | | | | | | | | | | | | | | | | | | | | | | | | | | | | | | | | | | | |
| | | | | | | | | | | | | | | | | | | | | | | | | | | | | | | | | | | | | | | | | | | | | | | | |
| | | | | | | | | | | | | | | | | | | | | | | | | | | | | | | | | | | | | | | | | | | | | | | | |

4.14.3 Capacity planning of the system bus

Each PDO telegram possesses a constant useful data content of 8 Bytes. According to worst case, this results in a maximum telegram length of 140 bits. The maximum telegram run time of the PDO's is thus stipulated via the set baud rate.

Capacity planning

| Baud rate / kBaud | Telegram run time / μ s |
|-------------------|-----------------------------|
| 1000 | 140 |
| 500 | 280 |
| 250 | 560 |
| 125 | 1120 |
| 100 | 1400 |
| 50 | 2800 |

As a function of the set baud rate and the transmission interval of the TxPDO's selected, the following bus loads results:

Capacity of the system bus

| Baud rate / kBaud | Bus load as a function of the transmission for one TxPDO in % | | | | | | | | | |
|-------------------|---|-----|------|-----|------|------|-----|------|------|------|
| | 1ms | 2ms | 3ms | 4ms | 5ms | 6ms | 7ms | 8ms | 9ms | 10ms |
| 1.000 | 14 | 7 | 4.7 | 3.5 | 2.8 | 2.3 | 2 | 1.8 | 1.6 | 1.4 |
| 500 | 28 | 14 | 9.3 | 7 | 5.6 | 4.7 | 4 | 3.5 | 3.1 | 2.8 |
| 250 | 56 | 28 | 18.7 | 14 | 11.2 | 9.3 | 8 | 7 | 6.2 | 5.6 |
| 125 | 112 | 56 | 37.3 | 28 | 22.4 | 18.7 | 16 | 14 | 12.4 | 11.2 |
| 100 | 140 | 70 | 46.7 | 35 | 28 | 23.3 | 20 | 17.5 | 15.6 | 14 |
| 50 | 280 | 140 | 93.3 | 70 | 56 | 46.7 | 40 | 35 | 31.1 | 28 |

Attention! A bus load >100% means that a telegram cannot be dispatched completely between two transmission times.

Such a setting is not admissible!

This observation must be done for each TxPDO. The sum of all the TxPDO's decides on the entire bus load. The bus load must be designed in such a way that any telegram repetitions for transmission errors are possible without exceeding the bus capacity.

Note: To facilitate capacity planning, an Microsoft Excel file with the name "Load_Systembus.xls" is available.

The capacity planning are planned and documented with the help of the table. The work sheet is available as a Microsoft Excel document "Load_Systembus.xls" on the BONFIGLIOLI VECTRON product CD or by request.

| Load system bus | | | |
|--|--------------|---------|--------------|
| Baud rate [kBaud]: 50, 100, 125, 250, 500, 1000 | | | 1000 |
| Frequency inverter | TxPDO Number | Ta [ms] | Workload [%] |
| 1 | 1 | 0 | 0 |
| | 2 | 0 | 0 |
| | 3 | 0 | 0 |
| 2 | 1 | 0 | 0 |
| | 2 | 0 | 0 |
| | 3 | 0 | 0 |
| 3 | 1 | 0 | 0 |
| | 2 | 0 | 0 |
| | 3 | 0 | 0 |
| 4 | 1 | 0 | 0 |
| | 2 | 0 | 0 |
| | 3 | 0 | 0 |
| 5 | 1 | 0 | 0 |
| | 2 | 0 | 0 |
| | 3 | 0 | 0 |
| 6 | 1 | 0 | 0 |
| | 2 | 0 | 0 |
| | 3 | 0 | 0 |
| 7 | 1 | 0 | 0 |
| | 2 | 0 | 0 |
| | 3 | 0 | 0 |
| 8 | 1 | 1 | 14 |
| | 2 | 1 | 14 |
| | 3 | 1 | 14 |
| 9 | 1 | 1 | 14 |
| | 2 | 1 | 14 |
| | 3 | 0 | 0 |
| 10 | 1 | 0 | 0 |
| | 2 | 0 | 0 |
| | 3 | 0 | 0 |
| Total workload [%] | | | 70 |

In the table, the set baud rate is entered from the parameter *Baud-Rate 903* in kBaud. For each frequency inverter, the set time for the transmission interval (e. g. *TxPDO1 Time 931*) in ms is entered for the TxPDO being used at the time. In the column **Load** the bus load caused by the individual TxPDO appears, under **Total Load** the entire bus load.

For the bus load (Total load) the following limits have been defined:

≤ 80 % → OKAY
 80 ... 90 % → CRITICAL
 > 90 % → NOT POSSIBLE

5 Control inputs and outputs

5.1 Analog input EM-S1INA

5.1.1 General

The analog input of the EM-ENC-01 expansion module can optionally be configured as a voltage or a current input. Parameterization of the input signal is done by the definition of a linear characteristic and assignment as a

- reference value source
(can be selected via the parameter *Reference frequency source* **475**),
- reference percentage source
(can be selected via the parameter *Reference percentage source* **476**),
- actual percentage source
(can be selected via the parameter *Actual percentage source* **478**, in configuration **x11**) or
- limit value sources
(can be selected via the parameter *Limit Source* **734...737**).

5.1.2 Configuration voltage/current input

The analog input of the EM-ENC-01 expansion module has been configured in the factory setting for a voltage signal of +/-10 V. Switch **S3** enables a switch-over of the operation mode for an analog current signal of +/-20 mA.

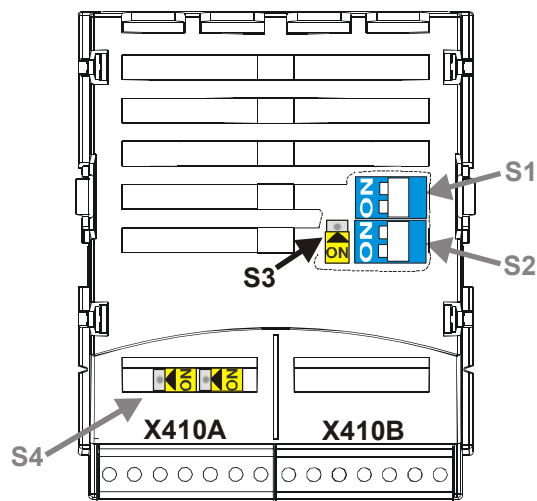

| Operation mode – switch S3 | Function |
|----------------------------|--|
| OFF -Voltage input | OFF (to the right) – analog input EM-S1INA is configured for a voltage signal. |
| ON -Current input | ON (to the left) – analog input EM-S1INA is configured for a current signal. |

Note: With the two switches **S1** and **S2**, the bus connection of the system bus interface is configured.
(see chapter "System bus interface")
The switches **S4** activate the termination resistance of 150 Ω for the speed sensor input according to specification RS422-A / RS-485.
(see chapter "Speed Sensor Input EM-ENC")

5.1.3 Characteristic

The mapping of the analog input signals onto a frequency or percentage reference value is possible for various demands. The parameterization is to be done via two points of the linear characteristic of the reference channel.

The characteristic point 1, with the coordinates X1 and Y1, and the characteristic point 2, with the coordinates X2 and Y2, are to be set in the four data sets.

The characteristic points X1 and X2 are stated as percentages, as the analog input can be switched as a current or voltage input via switch S3.

| Parameter | | Setting | | |
|-----------|-------------------------|-----------|----------|-------------|
| No. | Description | Min. | Max. | Fact. sett. |
| 564 | Characteristic point X1 | -100,00 % | 100,00 % | -98,00 % |
| 565 | Characteristic point Y1 | -100,00 % | 100,00 % | -100,00 % |
| 566 | Characteristic point X2 | -100,00 % | 100,00 % | 98,00 % |
| 567 | Characteristic point Y2 | -100,00 % | 100,00 % | 100,00 % |

The coordinates of the characteristic points are related as a percentage to the analog signal, with 10 V or 20 mA, and the parameter *Maximum Frequency* **419** or parameter *Maximum reference percentage* **519**. The change of direction of rotation can be done via the digital inputs and/or by selecting the characteristic points.

The definition of the analog input characteristic can be calculated via the two-point form of the straight line equation. The speed Y of the drive mechanism is controlled according to the analog control signal X.

$$Y = \frac{Y2 - Y1}{X2 - X1} \cdot (X - X1) + Y1$$

Attention: Monitoring of the analog input signal via the parameter *Error/Warning Behavior* **563** demands a check of the characteristic parameters. Sensible use is only possible if the *Characteristic point X1* **564** is in the positive range.

5.1.4 Operation modes

The operation modes of the analog input characteristic enable application-related scaling as a supplement to the characteristic points stated. One of the four linear types of characteristic is selected for adaptation of the signal for the analog input signal via the parameter *Operation mode* **562**.

If the characteristic points are not suited for the type of characteristic selected, the characteristic points are corrected internally.

| Operation mode | Function |
|--------------------------------------|---|
| 1 -bipolar | The analog input signal is mapped onto the reference figure according to the characteristic points (X1/Y1) and (X2/Y2). |
| 11 -unipolar | With a negative parameter value of the characteristic points X1 or X2, they are mapped to the reference value zero. |
| 21 -unipolar 2...10 V / 4...20 mA | If the characteristic points X1 or X2 have been set with a negative parameter figure or smaller than 0%, the input characteristic is mapped to the reference value 20%. |
| 101 -bipolar abs. value | Negative parameter values of the characteristic points Y1 or Y2 are mapped as a positive reference value in the characteristic. |

Further information on the operation modes stated in the table can be found in the following chapter "Examples".

5.1.4.1 Examples

The analog input signal is mapped onto a reference value as a function of the characteristic. The following examples show the operation modes for an analog voltage signal. The parameter *Minimum Frequency* **418** is set to the value 0.00 Hz. The characteristic point 100% for the Y axis corresponds to the parameter *Maximum Frequency* **419** of 50.00 Hz in the examples.

Attention! The various operation modes change the input characteristic as a function of the parameterized characteristic points. In the following examples, the areas of the system of coordinates from which a characteristic point is displaced are marked.

Operation mode "1 – bipolar"

In operation mode "1 – bipolar", the characteristic of the analog input can be freely set by stating two characteristic points.

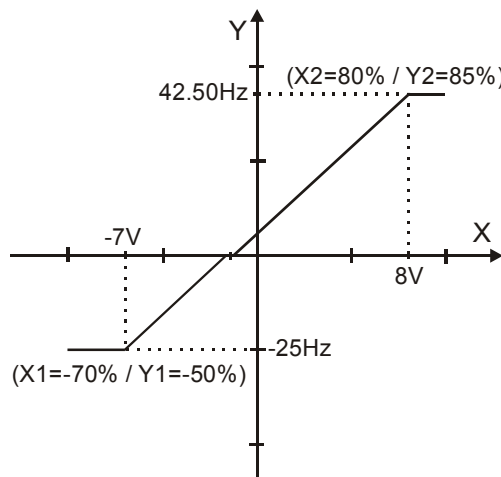

Characteristic point 1:
 $X1 = -70.00\% \cdot 10 \text{ V} = -7.00 \text{ V}$
 $Y1 = -50.00\% \cdot 50.00 \text{ Hz} = -25.00 \text{ Hz}$

Characteristic point 2:
 $X2 = 80.00\% \cdot 10 \text{ V} = 8.00 \text{ V}$
 $Y2 = 85.00\% \cdot 50.00 \text{ Hz} = 42.50 \text{ Hz}$

Tolerance band:
 $\Delta X = 2.00\% \cdot 10 \text{ V} = 0.20 \text{ V}$

The change of direction of rotation is done in the example at an analog input signal of -1.44 V, with a tolerance band of $\pm 0.20 \text{ V}$.

Operation mode "11 – unipolar"

In operation mode "11 – unipolar", the characteristic points are displaced to the origin of the characteristics with a negative value for the X axis.

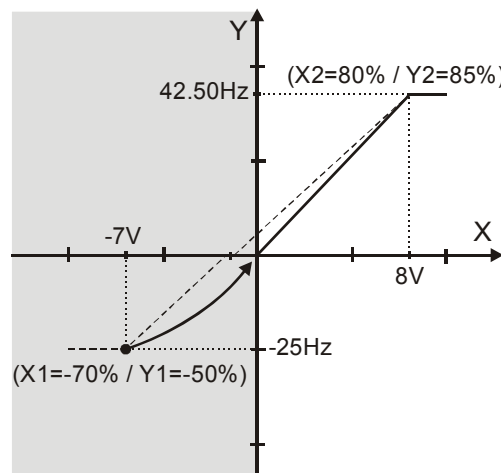

Characteristic point 1:
 $X1 = -70.00\% \cdot 10 \text{ V} = -7.00 \text{ V}$
 $Y1 = -50.00\% \cdot 50.00 \text{ Hz} = -25.00 \text{ Hz}$

Characteristic point 2:
 $X2 = 80.00\% \cdot 10 \text{ V} = 8.00 \text{ V}$
 $Y2 = 85.00\% \cdot 50.00 \text{ Hz} = 42.50 \text{ Hz}$

Tolerance band:
 $\Delta X = 2.00\% \cdot 10 \text{ V} = 0.20 \text{ V}$

The characteristic point 1 has been displaced to the origin. The parameter *Tolerance band* **560** is not taken into account in this example, as no change of sign of the reference frequency value takes place.

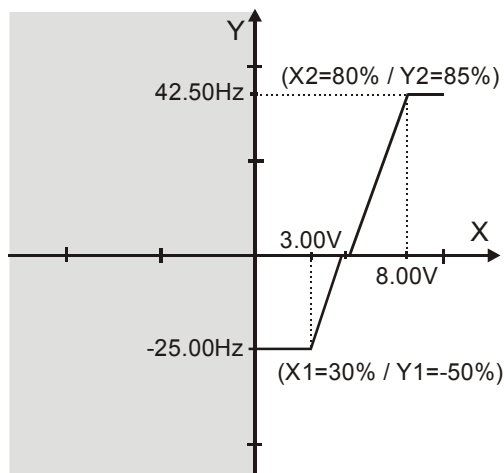

Characteristic point 1:
 $X1 = 30,00 \% \cdot 10 \text{ V} = 3.00 \text{ V}$
 $Y1 = -50,00 \% \cdot 50.00 \text{ Hz} = -25.00 \text{ Hz}$

Characteristic point 2:
 $X2 = 80,00 \% \cdot 10 \text{ V} = 8.00 \text{ V}$
 $Y2 = 85,00 \% \cdot 50.00 \text{ Hz} = 42.50 \text{ Hz}$

Tolerance band:
 $\Delta X = 2,00 \% \cdot 10 \text{ V} = 0.20 \text{ V}$

The change of direction of rotation is done in the example at an analog input signal of 4.85 V, with a tolerance band of $\pm 0.20 \text{ V}$.

Operation mode "21 – unipolar 2...10 V / 4...20 mA"

This operation mode limits the input characteristic to the range between 20% and 100% of the analog signal. If the value for a characteristic point of the X axis is outside 0%, it is mapped to the characteristic point (2 V / 0 Hz).

The characteristic point on the X axis is calculated according to the following formula:

characteristic point X = parameter value $X \cdot (100.00\% - 20.00\%) + 20.00\%$

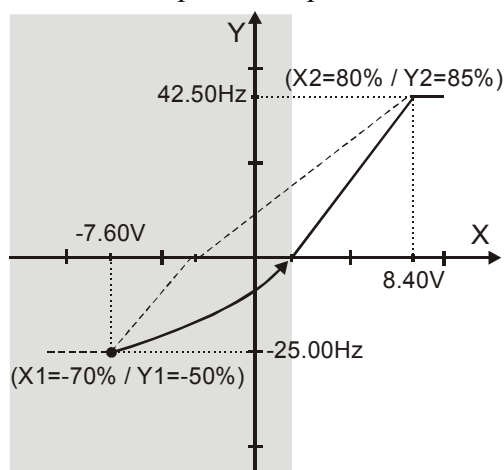

Characteristic point 1:
 $X1 = [-70.00\% \cdot (100.00\% - 20.00\%) + 20.00\%] \cdot 10 \text{ V} = -7.60 \text{ V}$
 $Y1 = -50.00\% \cdot 50.00 \text{ Hz} = -25.00 \text{ Hz}$

Characteristic point 2:
 $X2 = [80.00\% \cdot (100.00\% - 20.00\%) + 20.00\%] \cdot 10 \text{ V} = 8.40 \text{ V}$
 $Y2 = 85.00\% \cdot 50.00 \text{ Hz} = 42.50 \text{ Hz}$

Tolerance band:
 $\Delta X = [2.00\% \cdot (100.00\% - 20.00\%) \cdot 10 \text{ V}] = 0.16 \text{ V}$

The characteristic point 1 has been displaced to the point (2.00V / 0.00 Hz). The parameter *Tolerance band 560* is not taken into account in this example, as no change of sign of the reference frequency value takes place.

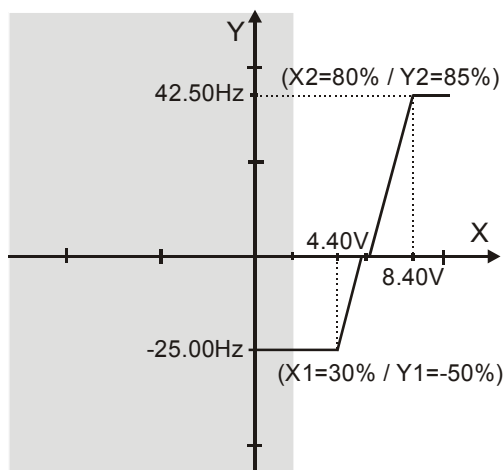

Characteristic point 1:
 $X1 = [30,00\% \cdot (100.00\% - 20.00\%) + 20.00\%] \cdot 10 \text{ V} = 4.40 \text{ V}$
 $Y1 = -50.00\% \cdot 50.00 \text{ Hz} = -25.00 \text{ Hz}$

Characteristic point 2:
 $X2 = [80.00\% \cdot (100.00\% - 20.00\%) + 20.00\%] \cdot 10 \text{ V} = 8.40 \text{ V}$
 $Y2 = 85.00\% \cdot 50.00 \text{ Hz} = 42.50 \text{ Hz}$

Tolerance band:
 $\Delta X = [2.00\% \cdot (100.00\% - 20.00\%) \cdot 10 \text{ V}] = 0.16 \text{ V}$

The change of direction of rotation is done in the example at an analog input signal of 5.88 V, with a tolerance band of $\pm 0.16 \text{ V}$.

Operation mode "101 – bipolar Abs. value"

The operation mode "101 – bipolar Abs. value" maps the bipolar analog signal onto a unipolar input characteristic. The formation of the absolute value takes the characteristic into account comparable to the "bipolar" operation mode, but the characteristic points are reflected on the X axis with a negative value for the Y axis.

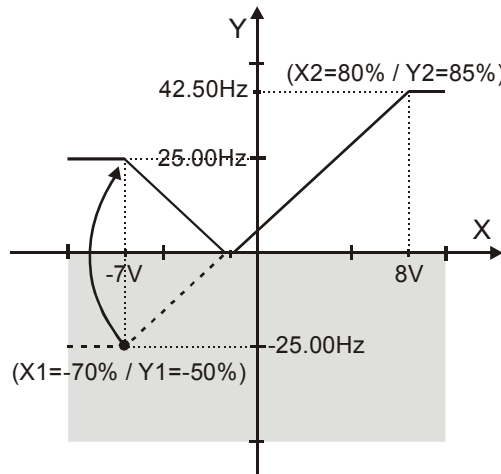

Characteristic point 1:

$$X1 = -70.00\% \cdot 10 \text{ V} = -7.00 \text{ V}$$

$$Y1 = -50.00\% \cdot 50.00 \text{ Hz} = -25.00 \text{ Hz}$$

Characteristic point 2:

$$X2 = 80.00\% \cdot 10 \text{ V} = 8.00 \text{ V}$$

$$Y2 = 85.00\% \cdot 50.00 \text{ Hz} = 42.50 \text{ Hz}$$

Tolerance band:

$$\Delta X = 2.00\% \cdot 10 \text{ V} = 0.20 \text{ V}$$

In this example, the reference value is again increased from an analog input signal of -1.44 V with a tolerance band of $\pm 0.20 \text{ V}$. The theoretical change of sign of the reference value is taken into account and leads to the tolerance band stated. There is no change of the direction of rotation.

5.1.5 Scaling

The analog input signal is mapped to the freely configurable characteristic. The maximum admissible setting range of the drive mechanism is to be set according to the configuration selected via the frequency limits or the percentage value limits. In the parameterization of a bipolar characteristic, the minimum and maximum limit for both directions of rotation are taken over. The percentage values of the characteristic points are relative to the maximum limits selected.

| Parameter | | Setting | | |
|-----------|-------------------|---------|-----------|-------------|
| No. | Description | Min. | Max. | Fact. sett. |
| 418 | Minimum Frequency | 0.00 Hz | 999.99 Hz | 3.50 Hz |
| 419 | Maximum Frequency | 0.00 Hz | 999.99 Hz | 50.00 Hz |

The controls use the maximum value of the output frequency, which is calculated from the *maximum frequency* **419** and the compensated slip of the drive mechanism. The frequency limits define the speed range of the drive mechanism and the reference percentage values supplement the scaling of the input characteristic according to the configured functions.

| Parameter | | Setting | | |
|-----------|------------------------------|---------|----------|-------------|
| No. | Description | Min. | Max. | Fact. sett. |
| 518 | Minimum reference percentage | 0.00 % | 300.00 % | 0.00 % |
| 519 | Maximum reference percentage | 0.00 % | 300.00 % | 100.00 % |

5.1.6 Tolerance band and hysteresis

The analog input characteristic with change of sign of the reference value can be adapted by the parameter *Tolerance band* **560** of the application. The tolerance band to be defined extends the zero crossing of the speed relative to the analog control signal. The percentage parameter value is relative to the maximum current or voltage signal.

| Parameter | | Setting | | |
|-----------|----------------|---------|---------|-------------|
| No. | Description | Min. | Max. | Fact. sett. |
| 560 | Tolerance band | 0.00 % | 25.00 % | 2.00 % |

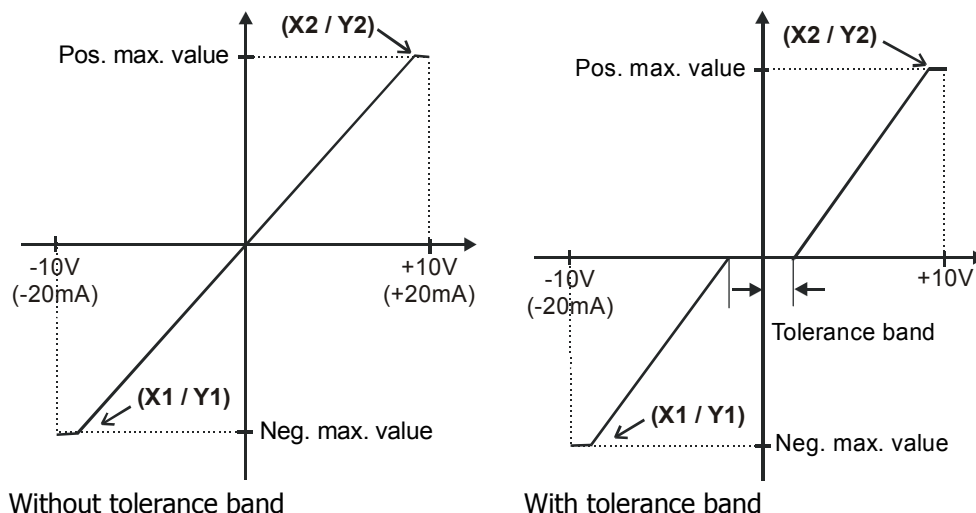

The *Minimum Frequency* **418** or the *Minimum reference percentage* **518** set in the factory extend the parameterized tolerance band to the hysteresis.

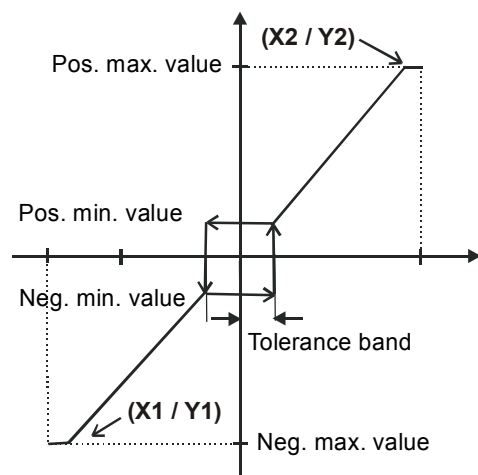

For example, the output variable coming from the positive input signals is kept at the positive minimum value until the input signal becomes smaller than the value for the tolerance band in a negative direction. Only then is there continuation on the set characteristic.

5.1.7 Error and warning behavior

The monitoring of the analog input signal necessary according to the application is to be configured via the parameter *Error/Warning behavior* **563**.

| Operation mode | Function |
|--------------------------------------|---|
| 0 -Off | The input signal is not monitored. |
| 1 -Warning < 1 V / 2 mA | If the input signal is smaller than 1 V or 2 mA, there is a warning message. |
| 2 -Shutdown < 1 V / 2 mA | If the input signal is smaller than 1 V or 2 mA, there is a warning message, the drive mechanism is decelerated according to stopping behavior 1. |
| 3 - Fault switch-off < 1 V / 2 mA | If the input signal is smaller than 1 V or 2 mA, there is a warning and fault message and the drive mechanism stops freely. |

The monitoring of the analog input signal is active independent of the release of the frequency inverter according to the operation mode selected.

In operation mode **2**, the drive mechanism is decelerated independent of the stopping behavior set (Parameter *Operation mode* **630**) according to stopping behavior 1 (shutdown and switch-off). If the set holding time has expired, there is a fault message. A repeat start of the drive mechanism is possible by switching the start signal on and off if the fault has been rectified beforehand.

Operation mode **3** defines the free stoppage of the drive mechanism, independent of the stopping behavior selected, which is stipulated with the parameter *Stop function* **630**.

Attention! Monitoring of the analog input signal via the parameter *Error/Warning Behavior* **563** demands a check of the characteristic parameters.

5.1.8 Adjustment

As a result of component tolerances, it can be necessary to adjust the analog input. Parameter *Adjustment* **568** is used for this purpose.

| Operation mode | Function |
|-----------------------------|---|
| 0 - no adjustment | Normal operation |
| 1 - Adjustment 0 V / 0 mA | Adjustment of the measurement with an analog signal of 0 V or 0 mA. |
| 2 - Adjustment 10 V / 20 mA | Adjustment of the measurement with an analog signal of 10 V or 20 mA. |

Example of the adjustment of the analog input with a voltage signal:

Note: The measurements for the adjustment are to be done with a suitable measuring instrument and the correct polarity. If not, faulty measurements can result.

- Apply 0 V to the analog input; e.g. with a bridge from the terminal of the analog input X410B.4 to terminal X210B.7 (earth/GND) of the frequency inverter.
- Select operation mode "1 - Adjustment 0 V / 0 mA".
- Apply 10 V to the analog input; e.g. with a bridge from the terminal of the analog input to terminal X210B.5 (reference output 10 V) of the frequency inverter.
- Select operation mode "2 - Adjustment 10 V / 20 mA".

5.1.9 Filter time constant

The time constant of the filter for the reference analog value can be set via the parameter *Filter time constant* **561**.

The time constant states the time for which the input signal is averaged by means of a low pass, e.g. in order to eliminate fault effects.

The setting range is a range of values between 0 ms and 5000 ms in 15 steps.

| Operation mode | Function |
|------------------------------|---|
| 0 - Time constant 0 ms | Filter deactivated – analog reference value is forwarded unfiltered |
| 2 - Time constant 2 ms | Filter activated – averaging of the input signal via the set value of the filter time constants |
| 4 - Time constant 4 ms | |
| 8 - Time constant 8 ms | |
| 16 - Time constant 16 ms | |
| 32 - Time constant 32 ms | |
| 64 - Time constant 64 ms | |
| 128 - Time constant 128 ms | |
| 256 - Time constant 256 ms | |
| 512 - Time constant 512 ms | |
| 1000 - Time constant 1000 ms | |
| 2000 - Time constant 2000 ms | |
| 3000 - Time constant 3000 ms | |
| 4000 - Time constant 4000 ms | |
| 5000 - Time constant 5000 ms | |

5.2 Speed sensor input EM-ENC

The 4 speed sensor inputs of the EM-ENC-01 expansion module can be set via the parameter *Operation mode Speed sensor 2* **493** and selection of the corresponding operation mode for the evaluation of a unipolar 24V two-channel speed sensor (incremental speed sensor).

With the help of parameter *Operation mode Speed sensor 2* **493**, the following operation modes are available:

| Operation mode | Function |
|-------------------------------------|--|
| 0 - Off | Speed measurement not active |
| 4 - Quadruple evaluation | Two-channel speed sensor with recognition of direction of rotation via track signals A and B; four signal edges are evaluated per division mark. |
| 104 - Quadruple evaluation inverted | As operation mode 4; the actual speed value is inverted. (Alternative to exchanging the track signals). |

Unlike the standard control terminals available according to specification RS-422A / RS-485, the interface is suitable for a 5 V push-pull signal.

5.2.1 Termination resistor

The termination resistance of 150 Ω for the speed sensor of the EM-ENC-01 speed sensor is deactivated by default.



Caution! The termination resistance may only be activated for a 5 V push-pull signal according to specification RS-422A / RS-485. For activating the termination resistance, **both** slide switches **S4** must be switched to position "ON". Switching of the two slide switches to different positions may destroy components. If a unipolar speed sensor is used, e.g. with a 24V signal, no termination resistance is required.

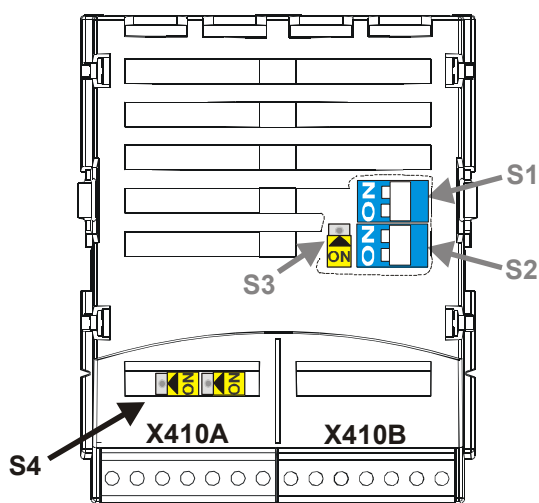

| Operation mode of switches S4 | Function |
|---------------------------------|--------------------|
| OFF - no termination resistance | OFF (to the right) |
| ON - Termination resistance | ON (to the left) |

Note: With the two switches **S1** and **S2**, the bus connection of the system bus interface is configured. (see chapter "System bus interface")
Switch **S3** enables switching the analog input to voltage signal or current signal. (see chapter "Analog input EM-S1INA")

Terminal assignment of the inputs:

| Socket X410A | |
|--------------|------------------------------------|
| Terminal | Input |
| (1): X410A.1 | Speed sensor input EM-ENC track A+ |
| (2): X410A.2 | Speed sensor input EM-ENC track A- |
| (3): X410A.3 | Speed sensor input EM-ENC track B+ |
| (4): X410A.4 | Speed sensor input EM-ENC track B- |

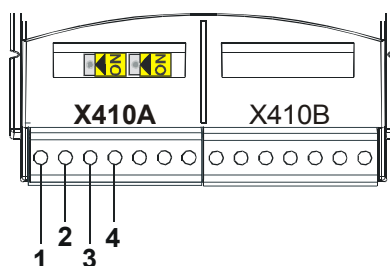

5.2.2 Division marks

The number of increments of the connected speed sensor can be parameterized via the parameter *Division marks speed sensor 2* **494**. The number of division marks of the speed sensor is to be selected according to the speed range of the application. The maximum number of division marks S_{max} is defined by the limit frequency of $f_{max} = 300$ kHz of the speed sensor inputs EM-ENC (track A) and EM-ENC (track B).

$$S_{max} = 300000 \text{ Hz} \cdot \frac{60 \text{ s/min}}{n_{max}} \quad n_{max} = \text{Max. speed of the motor in RPM}$$

To ensure a good true running of the drive mechanism, a sensor signal must be evaluated at least every 2 ms (signal frequency $f = 500$ Hz). The minimum number of division marks S_{min} of the incremental speed sensor for a required minimum speed n_{min} can be calculated from this requirement. The evaluation of four signal edges per mark is firmly defined in the function of speed sensor 2.

$$S_{min} = 500 \text{ Hz} \cdot \frac{60 \text{ s/min}}{A \cdot n_{min}} \quad n_{min} = \text{Min. speed of the motor in RPM}$$

$A = 4$ (quadruple evaluation)

| Parameter | | Setting | | |
|-----------|-------------------------------|---------|------|-------------|
| No. | Description | Min. | Max. | Fact. sett. |
| 494 | Division marks speed sensor 2 | 1 | 8192 | 1024 |

Via the parameter *Operation mode Level* **495**, the following operation modes can be selected:

| Operation mode | Function |
|----------------|--|
| 0 - push-pull | Push-pull signals (5 V) are evaluated (according to specification RS-422A/RS-485). |
| 2 - unipolar | Unipolar signals (10 V...24 V) at A+ and B+ are evaluated. |

5.2.3 Actual speed source

If speed sensor 2 of the expansion module is configured to supply the actual value signal for the speed controller, speed sensor 2 must be selected as the source. Switchover is affected via parameter *Actual Speed Source* **766**. By default, speed sensor 1 is used as the actual speed source.

| Operation mode | Function |
|--------------------|--|
| 1 - Speed sensor 1 | The actual speed source is speed sensor 1 of the basic device (factory setting). |
| 2 - Speed sensor 2 | The actual speed source is speed sensor 2 of the EM-ENC-01 expansion module. |

5.2.4 Actual value comparison

The expansion module provides additional operation modes for parameters *Operation Mode Comparator 1* **540** and *Operation Mode Comparator 2* **543** which are described in the operating instructions. These operation modes permit a comparison of the speed frequency of speed sensor 2 with a maximum speed and a comparison of the analog input EM-S1INA with a maximum analog input value.

| Operation mode | Function |
|-----------------------------|---|
| 8 -Abs. actual speed 2 | <i>Speed Sensor 2 Speed</i> 220 > maximum speed (calculated from <i>Maximum Frequency</i> 419 and <i>No. of Pole Pairs</i> 373) |
| 16 -EM-S1INA absolute value | <i>Analog input EM-S1INA</i> 253 > analog input100% |
| 108 and 116 | Operation modes with signs (+/-) |

5.3 Frequency and percentage reference channel

The varied functions for the specification of the reference values are connected in the various configurations by the frequency or percentage reference channel. The *Reference frequency source* **475**, and the *Reference percentage source* **476** determine the additive connection of the available reference sources as a function of the installed hardware.

| Operation mode | Function |
|--|---|
| 2 - EM-S1INA, absolute value | Reference source is the analog input EM-S1INA |
| 4 - MFI1A + EM-S1INA, absolute value | Reference sources are the multifunctional input MFI1A and the analog input EM-S1INA |
| 12 - EM-S1INA + FF (and/or FP), absolute value | Reference sources are the analog input EM-S1INA and fixed frequency FF (and/or the fixed percentage FP). |
| 14 - MFI1A + EM-S1INA + FF (and/or FP), absolute value | Reference sources are the multifunctional input MFI1A, analog input EM-S1INA and fixed frequency FF (and/or the fixed percentage FP). |
| 22 - EM-S1INA + MP, absolute value | Reference sources are the analog input EM-S1INA and the motor potentiometer function MP. |
| 24 - MFI1A + EM-S1INA + MP, absolute value | Reference sources are the multifunctional input MFI1A, analog input EM-S1INA and the motor potentiometer function MP |
| 34 - speed sensor 2 (F2), absolute value | The frequency signals in <i>Operation mode Speed sensor 2</i> 493 are evaluated as a reference value. |
| 35 - MFI1A + F2, absolute value | Reference sources are the multifunctional input MFI1A and the frequency signals in <i>Operation Mode Speed Sensor 2</i> 493 . |
| 102 to 135 | Operation modes with signs (+/-) |

Additional to the operation modes listed, those stated in the operating instructions of the frequency inverter in the chapter "Frequency reference channel", and in the chapter "Percentage reference channel" also apply.

5.4 Actual value display

The actual value of speed sensor 2 can be read via the parameters *Encoder frequency 2* **219** and *Encoder speed 2* **220**.

The analog input signal on analog input EM-S1INA can be a voltage or a current signal depending on the setting of switch **S3**. Accordingly, the actual value parameter *Analog input EM-S1INA* **253** is displayed as a percentage.

5.5 Repetition frequency output EM-RFOUT

The repetition frequency output EM-RFOUT emulates a speed sensor which is installed at the motor. The mechanical rotational frequency and/or speed measured at the motor shaft depends on the electrical frequency and the parameterized number of pole pairs of the motor.

Note: The value selected with parameter *No. of Pole Pairs* **373**, is taken into account for the calculation of the repetition frequency according to the selected data set.

assignment of the outputs:

Repetition frequency output EM-RFOUT (X410A.7): track A+
 Repetition frequency output EM-RFOUT (X410B.1): track A-
 Repetition frequency output EM-RFOUT (X410B.2): track B+
 Repetition frequency output EM-RFOUT (X410B.3): track B-

The functionality of the repetition frequency output EM-RFOUT is defined by the parameter *Operation mode Repetition Frequency* **546**.

| Operation mode | Function |
|---|---|
| 0 - Off | The repetition frequency output EM-RFOUT is deactivated |
| 101 - Frequency speed sensor 1 wo. corr. | The repetition frequency is proportional to speed sensor input 1 (basic device) |
| 102 - Frequency speed sensor 2 wo. corr. (SW) | The repetition frequency is proportional to speed sensor input 2 (expansion module) |
| 104 - Act. frequency wo. corr. | The repetition frequency is proportional to parameter <i>Actual Frequency</i> 241 |
| 105 - Reference frequency wo. corr. | The repetition frequency is proportional to parameter <i>Reference Frequency</i> 228 |
| 111 to 115 | Operating modes 101 through 105 with delay according to parameter <i>Ramp</i> 548 in case the output signal at the frequency inverter is switched off or inhibited |
| 202 - Frequency speed sensor 2 (HW) | The repetition frequency is proportional to speed sensor input 2 (expansion module), without conversion by parameter <i>Division Marks</i> 547 |

5.5.1 Division marks

The repetition frequency output EM-RFOUT can be parameterized via the parameter *Division Marks* **547** like an incremental speed sensor.

| Parameter | | Setting | | |
|-----------|----------------|---------|------|-------------|
| No. | Description | Min. | Max. | Fact. sett. |
| 547 | Division marks | 30 | 8192 | 1024 |

The maximum number of division marks S_{\max} is defined by the limit frequency of $f_{\max} = 150 \text{ kHz}$ of the digital outputs EM-RFOUT.

$$S_{\max} = 150000 \text{ Hz} \cdot \frac{p}{f_{\max}}$$

$p = \text{No. of Pole Pairs } \mathbf{373}$
 $f_{\max} = \text{max. frequency of operation mode}$

5.5.2 Ramp

The repetition frequency is output according to the functionality defined with the parameter *Operation Mode Repetition Frequency* **546**. In operation modes 111 through 115, the functionality is extended for operating points without output signal of the frequency inverter. If the controller enable control signal is switched off or if the output signals of the frequency inverter are inhibited due to an error, the repetition frequency is reduced according to the delay adjusted with parameter *Ramp* **548**.

| Parameter | | Setting | | |
|-----------|-------------|-----------|--------------|-------------|
| No. | Description | Min. | Max. | Fact. sett. |
| 548 | Ramp | 0.01 Hz/s | 9999.99 Hz/s | 1.00 Hz/s |

5.5.3 Examples

The frequency signal is mapped on the repetition frequency output depending on the operation mode selected. The following examples illustrate the different operation modes for defined *Division Marks* **547** and *Ramp* **548**.

Operation mode "101- Frequency speed sensor 1 wo. corr."

Operation mode "101 – Frequency speed sensor 1 wo. corr." defines a repetition frequency which is proportional to the input signal at the control terminals of the frequency inverter.

The motor rating *No. of Pole Pairs* **373** is 2 and parameter *Division Marks* **547** is 1024.

The actual value *Frequency Speed Sensor 2* **219** has a value of 50.00 Hz. The mechanical rotational frequency of the motor at the current operating point is 25.00 Hz (speed $n=1500\text{min}^{-1}$) at a *No. of Pole Pairs* **373** of 2.

$$f = \frac{50.00 \text{ Hz}}{2} \cdot 1024 = 25600 \text{ Hz}$$

| | |
|--|------------|
| <i>Frequency speed sensor 2</i> 219 | = 50.00 Hz |
| <i>No. of Pole Pairs</i> 373 | = 2 |
| <i>Division Marks</i> 547 | = 1024 |

The repetition frequency to be expected in this example is the product of the current mechanical rotational frequency of 25.00 Hz and the parameterized no. of *Division Marks* **547** of 1024 division marks.

Operation mode "111 - Frequency speed sensor 1 wo. corr. w. ramp"

Operation mode "111 - Frequency speed sensor 1 wo. corr. w. ramp" adds the delay specified by parameter *Ramp* **548** to the above example.

The motor rating *No. of Pole Pairs* **373** is 2 and parameter *Division Marks* **547** is 1024. The delay is set by parameter *Ramp* **548** at 1.00 Hz/s.

The actual value *Frequency Speed Sensor 2* **219** has a value of 50.00 Hz. The mechanical rotational frequency of the motor at the current operating point is 25.00 Hz (speed $n=1500\text{min}^{-1}$) at a *No. of Pole Pairs* **373** of 2.

$$t = \frac{50.00 \text{ Hz}}{1.00 \frac{\text{Hz}}{\text{s}}} = 50.00 \text{ s}$$

| | |
|--|-------------|
| <i>Frequency speed sensor 2</i> 219 | = 50.00 Hz |
| <i>Ramp</i> 548 | = 1.00 Hz/s |

The delay to be expected in this example is 50 seconds until the repetition frequency output has reached the output signal 0.00 Hz.

6 Parameter list







The parameter list is structured according to the menu branches of the control unit. For better clarity, the parameters are marked with pictograms:

-  The parameter is available in the four data sets
- The parameter value is set by the SETUP routine
- This parameter cannot be written in the operation of the frequency inverter

6.1 Actual value menu (VAL)

| Actual values of the machine | | | | |
|---|--------------------------|------|----------------|---------|
| No. | Description | Unit | Display range | Chapter |
| 219 | Frequency speed sensor 2 | Hz | 0.0 ... 999.99 | 5.4 |
| 220 | Speed, speed sensor 2 | rpm | 0 ... 60000 | 5.4 |
| Actual values of the frequency inverter | | | | |
| 253 | Analog input EM-S1INA | % | -100 ... +100 | 5.4 |
| Actual values of the system bus | | | | |
| 978 | Node-State | - | 1 ... 3 | 4.12 |
| 979 | CAN-State | - | 1 ... 3 | 4.12 |

6.2 Parameter menu (PARA)

| Speed sensor 2 | | | | | |
|---|-------------|-------------------------------------|---------------|--------------------|-------|
| No. | Description | Unit | Setting range | Chapter | |
| <input checked="" type="checkbox"/> | 493 | Operation mode speed sensor 2 | - | Selection | 5.2 |
| <input checked="" type="checkbox"/> | 494 | Division marks speed sensor 2 | - | 1 ... 8192 | 5.2.2 |
| | 495 | Level | - | Selection | 5.2.2 |
| Repetition frequency | | | | | |
| | 546 | Operation mode repetition frequency | - | Selection | 5.5 |
| | 547 | Division marks repetition frequency | - | 30 ... 8192 | 5.5.1 |
| | 548 | Ramp | Hz/s | 0.01 ... 9999.99 | 5.5.2 |
| Analog input | | | | | |
|  | 560 | Tolerance band | % | 0.00 ... 25.00 | 5.1.6 |
| | 561 | Filter time constant | - | Selection | 5.1.9 |
| | 562 | Operation mode | - | Selection | 5.1.4 |
| | 563 | Error/warning behavior | - | Selection | 5.1.7 |
|  | 564 | Characteristic point X1 | % | -100.00 ... 100.00 | 5.1.3 |
|  | 565 | Characteristic point Y1 | % | -100.00 ... 100.00 | 5.1.3 |
|  | 566 | Characteristic point X2 | % | -100.00 ... 100.00 | 5.1.3 |
|  | 567 | Characteristic point Y2 | % | -100.00 ... 100.00 | 5.1.3 |
| | 568 | Adjustment | - | Selection | 5.1.8 |
| Speed controller | | | | | |
|  | 766 | Actual speed source | - | Selection | 5.2.3 |
| System bus | | | | | |
| | 900 | Node-ID | - | -1 ... 63 | 4.5 |
| | 903 | Baud-Rate | - | Selection | 4.4 |
| | 904 | Boot-Up Delay | ms | 3500 ... 50000 | 4.8.4 |
| | 918 | SYNC-Identifier | - | 0 ... 2047 | 4.8.2 |
| | 919 | SYNC-Time | ms | 0 ... 50000 | 4.9.2 |

| System bus | | | | |
|------------|--------------------|------|---------------|----------|
| No. | Description | Unit | Setting range | Chapter |
| 921 | RxSDO1-Identifier | - | 0 ... 2047 | 4.9.4 |
| 922 | TxSDO1-Identifier | - | 0 ... 2047 | 4.9.4 |
| 923 | SDO2 Set Active | - | Selection | 4.9.4 |
| 924 | RxPDO1-Identifier | - | 0 ... 2047 | 4.11.1 |
| 925 | TxPDO1-Identifier | - | 0 ... 2047 | 4.11.1 |
| 926 | RxPDO2-Identifier | - | 0 ... 2047 | 4.11.1 |
| 927 | TxPDO2-Identifier | - | 0 ... 2047 | 4.11.1 |
| 928 | RxPDO3-Identifier | - | 0 ... 2047 | 4.11.1 |
| 929 | TxPDO3-Identifier | - | 0 ... 2047 | 4.11.1 |
| 930 | TxPDO1 Function | - | Selection | 4.11.2 |
| 931 | TxPDO1 Time | ms | 0 ... 50000 | 4.11.2 |
| 932 | TxPDO2 Function | - | Selection | 4.11.2 |
| 933 | TxPDO2 Time | ms | 0 ... 50000 | 4.11.2 |
| 934 | TxPDO3 Function | - | Selection | 4.11.2 |
| 935 | TxPDO3 Time | ms | 0 ... 50000 | 4.11.2 |
| 936 | RxPDO1 Function | - | Selection | 4.11.2 |
| 937 | RxPDO2 Function | - | Selection | 4.11.2 |
| 938 | RxPDO3 Function | - | Selection | 4.11.2 |
| 939 | SYNC Timeout | ms | 0 ... 60000 | 4.11.3 |
| 941 | RxPDO1 Timeout | ms | 0 ... 60000 | 4.11.3 |
| 942 | RxPDO2 Timeout | ms | 0 ... 60000 | 4.11.3 |
| 945 | RxPDO3 Timeout | ms | 0 ... 60000 | 4.11.3 |
| 946 | TxPDO1 Boolean1 | - | Selection | 4.11.5.1 |
| 947 | TxPDO1 Boolean2 | - | Selection | 4.11.5.1 |
| 948 | TxPDO1 Boolean3 | - | Selection | 4.11.5.1 |
| 949 | TxPDO1 Boolean4 | - | Selection | 4.11.5.1 |
| 950 | TxPDO1 Word1 | - | Selection | 4.11.5.1 |
| 951 | TxPDO1 Word2 | - | Selection | 4.11.5.1 |
| 952 | TxPDO1 Word3 | - | Selection | 4.11.5.1 |
| 953 | TxPDO1 Word4 | - | Selection | 4.11.5.1 |
| 954 | TxPDO1 Long1 | - | Selection | 4.11.5.1 |
| 955 | TxPDO1 Long2 | - | Selection | 4.11.5.1 |
| 956 | TxPDO2 Boolean1 | - | Selection | 4.11.5.1 |
| 957 | TxPDO2 Boolean2 | - | Selection | 4.11.5.1 |
| 958 | TxPDO2 Boolean3 | - | Selection | 4.11.5.1 |
| 959 | TxPDO2 Boolean4 | - | Selection | 4.11.5.1 |
| 960 | TxPDO2 Word1 | - | Selection | 4.11.5.1 |
| 961 | TxPDO2 Word2 | - | Selection | 4.11.5.1 |
| 962 | TxPDO2 Word3 | - | Selection | 4.11.5.1 |
| 963 | TxPDO2 Word4 | - | Selection | 4.11.5.1 |
| 964 | TxPDO2 Long1 | - | Selection | 4.11.5.1 |
| 965 | TxPDO2 Long2 | - | Selection | 4.11.5.1 |
| 966 | TxPDO3 Boolean1 | - | Selection | 4.11.5.1 |
| 967 | TxPDO3 Boolean2 | - | Selection | 4.11.5.1 |
| 968 | TxPDO3 Boolean3 | - | Selection | 4.11.5.1 |
| 969 | TxPDO3 Boolean4 | - | Selection | 4.11.5.1 |
| 972 | TxPDO3 Word1 | - | Selection | 4.11.5.1 |
| 973 | TxPDO3 Word2 | - | Selection | 4.11.5.1 |
| 974 | TxPDO3 Word3 | - | Selection | 4.11.5.1 |
| 975 | TxPDO3 Word4 | - | Selection | 4.11.5.1 |
| 976 | TxPDO3 Long1 | - | Selection | 4.11.5.1 |
| 977 | TxPDO3 Long2 | - | Selection | 4.11.5.1 |
| 989 | Emergency Reaction | - | Selection | 4.8.3 |

7 Annex

7.1 Error messages

The various control functions and methods and the hardware of the frequency inverter contain functions, which continuously monitor the application. As a supplement to the messages documented in these operating instructions, the following failure keys are activated by the EM-ENC-01 expansion module.

| Control connections | | |
|---------------------|----|--|
| F14 | 02 | Reference value signal on analog input EM-S1INA faulty, check signal |
| | 30 | Speed sensor signal is faulty, check connections |
| | 31 | One track of the speed sensor signal is missing, check connections |
| | 32 | Direction of rotation of speed sensor wrong, check connections |

| System bus | | |
|------------|----|---|
| F21 | nn | Fault report to system bus master in fault in system bus slave nn = Node ID of slave (hex) |

| System bus | | |
|------------|----|--|
| F22 | 00 | Communication fault, system bus, timeout SYNC telegram |
| | 01 | Communication fault, system bus, timeout RxPDO1 |
| | 02 | Communication fault, system bus, timeout RxPDO2 |
| | 03 | Communication fault, system bus, timeout RxPDO3 |
| | 10 | Communication fault, system bus, bus OFF |

Additional to the listed fault messages, there are further fault messages for internal purposes and not listed here. If you receive fault messages, which are not listed here, please contact us by phone.



Bonfiglioli has been designing and developing innovative and reliable power transmission and control solutions for industry, mobile machinery and renewable energy applications since 1956.

www.bonfiglioli.com